

Dryaire Desiccant System

310595L

EN

Model 6760, Series D

Maximum Operating Pressure: 160 PSI (1.1 MPa, 11 bar)



Important Safety Instructions

Read all warnings and instructions in this manual.
Save these instructions.

Specifications

STAGE 1 - Air Filter with Automatic Drain (Part No. 22601, Series B)

Provides removal of water and contaminants down to 3 microns.

Air Inlet 1/2 in. F.P.T.

Air Outlet 1/2 in. F.P.T.

Air Flow Capacity 100 cfm (3 m³/min.) at 100 psi (0.7 MPa, 7 bar)

Max. Operating Pressure 175 psi (1.2 MPa, 12 bar)

Max. Temperature 150 °F (65 °C)

STAGE 2 - Coalescer with Automatic Drain (Part No. 22602, Series B)

Provides removal of oil and sub-micronic particles down to 1 micron.

Air Inlet 1/2 in. F.P.T.

Air Outlet 1/2 in. F.P.T.

Air Flow Capacity 83 cfm (1 m³/min.) at 100 psi (0.7 MPa, 7 bar)

Max. Operating Pressure 175 psi (1.2 MPa, 12 bar)

Max. Temperature 150 °F (65 °C)

STAGE 3 - Desiccant Housing (Part No. 22603, Series B)

Provides removal of uncondensed moisture.

Air Inlet 3/4 in. F.P.T. (reduced to 1/2 in.)

Air Outlet 3/4 in. F.P.T. (reduced to 3/8 in.)

Air Flow Capacity 30 cfm (0.84 m³/min.) at 100 psi (0.7 MPa, 7 bar)

Max. Operating Pressure 175 PSI (1.2 MPa, 12 bar)

Max. Temperature 150 °F (65 °C)

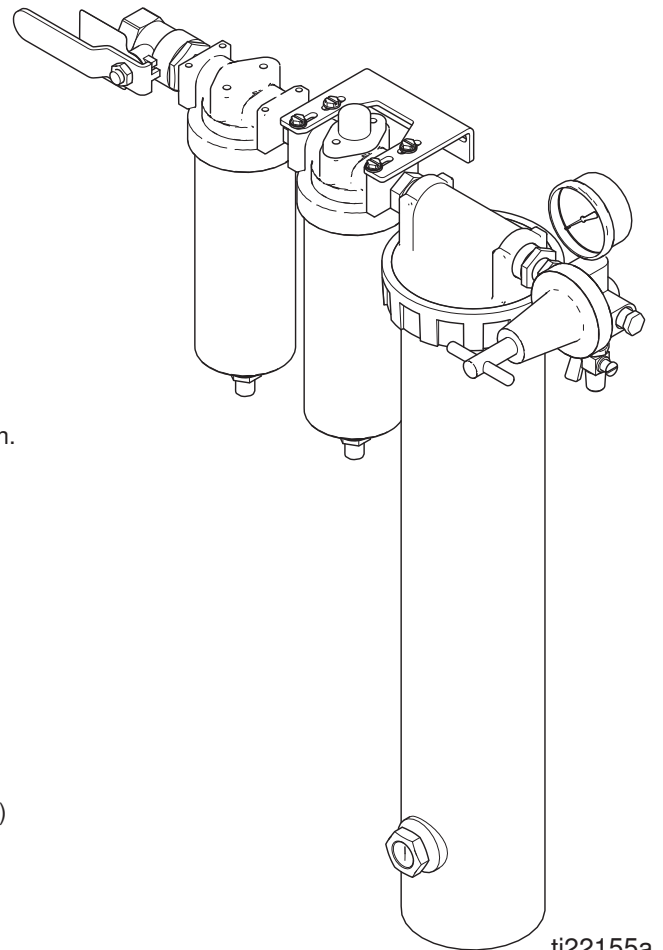

Model 6760
Desiccant Air Drying System

ti22155a

DRYAIR DESICCANT SYSTEM

System Description

Sharpe's DRYAIR Desiccant Air Drying System is the painter's insurance for removing dirt, water, oil, and uncondensed moisture from compressed air lines. Sharpe's Model 6760 Desiccant System includes 100% Indicating Silica Gel Desiccant which provides a higher moisture retention than competitors' units using activated alumina.

Sharpe's 3-Stage Point-of-Use System comes assembled and is simple to install.

Approved for Paint Company warranty programs when applying today's state-of-the-art refinish materials.

Ideal for protecting moisture sensitive tools.

System Includes:

- Air Filter with Automatic Drain (Part No. 22601)
- Coalescer with Automatic Drain (Part No. 22602)
- Desiccant Housing (Part No. 22603)
- Self Relieving Air Regulator
- Silica Gel Desiccant (5 lb can)
- Mounting Bracket Kit, Fittings, and Shut-Off Valve

Installation

1. Install Air Drying System as close as possible to the point where the air is being used. Install the bracket on the wall before attaching it to the coalescer.
2. Install main shut-off valve (part no. 22695) upstream of air system to allow maintenance of the unit.
3. Install system with air flow through filters in the direction noted on top of units.
4. Minimum 1/2 in. NPT piping is recommended. Avoid using many fittings, couplings, etc. that restrict air flow.
5. Maximum operating pressure and operating temperature of system is 160 psig (1.03 MPa, 10.3 bar) and 150°F (65°C).

Operation

After the system is installed and ready to use:

1. Attach air hose(s) to outlet valve.
2. Open main shut-off valve upstream of system.
3. Adjust regulator to desired setting by turning T-handle adjusting screw in or out.
4. Open outlet valve to supply air to spray guns or tool being used.
5. With air flowing, readjust air pressure at regulator if necessary.

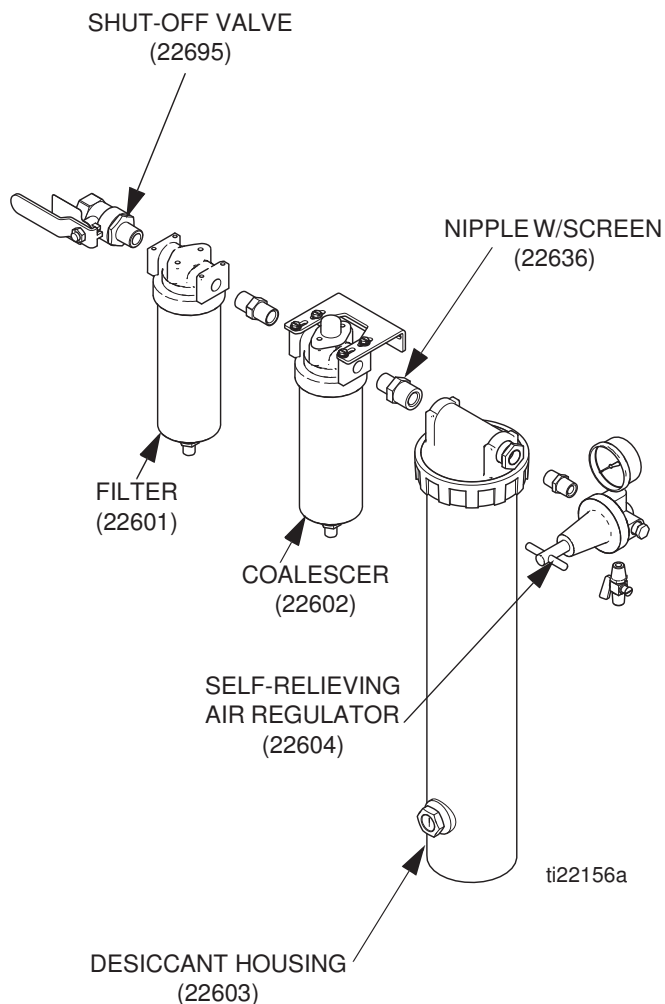

Warning

RISK OF INJURY. BE SURE TO RELEASE ALL AIR PRESSURE FROM SYSTEM BEFORE SERVICING UNIT.

Maintenance

1. Check system at least once per shift to insure proper drainage.
2. Before performing maintenance on system, close main shut-off valve located upstream. Bleed off residual air in system.
3. Unscrew the metal collar holding the desiccant bowl to head and remove bowl and collar.
4. Dump old desiccant out of bowl. (See **Desiccant Changeout**, page 7.)
5. If the pressure drop across the dryer has become unacceptable, the bronze element in bottom of bowl may have become clogged. If this happens, blow air through the flow tube by placing a blow gun at the top of the tube. If element replacement is needed, disassemble flow tube from bowl by removing the end cap and bottom nut from the bottom of the bowl, remove flow tube (hand tight) by turning counter clockwise and replace elements. Reverse instructions to reassemble.
6. Refill bowl with new or regenerated desiccant. Model 6760 holds 5 lb of desiccant. To regenerate Silica Gel Desiccant, heat desiccant for 4 hours at 275°F (135°C). To change and reorder desiccant, see **Desiccant Changeout**, page 7.
7. Reassemble bowl to head making sure that the o-ring (part no. 22663) in head is in place.

DESICCANT BEADS ARE NON-TOXIC AND NON-FLAMMABLE.

24V097 Complete Repair Kit

Includes 5 lb of chemical desiccant, filter element for air filter; filter element and o-ring for coalescer; and filter element, gasket and o-rings for desiccant housing.

Why Use Sharpe's Dryaire Desiccant System?

When air is compressed, the temperature of the air is increased as is its capacity to hold moisture. As the hot moist air travels downstream through the lines, it cools, allowing the moisture to condense. Filters, drain traps, and driplegs are effective for removing liquid condensate. But for removing residual water vapor and aerosols, you need a Sharpe Desiccant Air Drying System.

As the wet compressed air flows through the inlet port and down the bed of desiccant, the desiccant (silica gel) beads absorb the water vapor and aerosols. The silica gel beads are so effective in absorption, the air humidity can be reduced down to a -40°F (-40°C) pressure dewpoint. Unless your compressed air is exposed to a temperature below the dewpoint, there will be no further condensation forming in your air lines.

The microscopic pores of each silica gel bead are structured to attract and hold large capacities of moisture and prevent it from traveling downstream.

After the moisture has been removed, the dry air passes through a sintered bronze element, up the center tube, and out the outlet port. As long as the desiccant is replaced at saturation point, your equipment will receive ultra-dry, moisture-free air.

As the desiccant becomes saturated with moisture, the dew point begins to rise. This is evident when the desiccant changes color (see chart below), indicating the need for desiccant replacement. Refer to **Desiccant Changeout**, page 7.

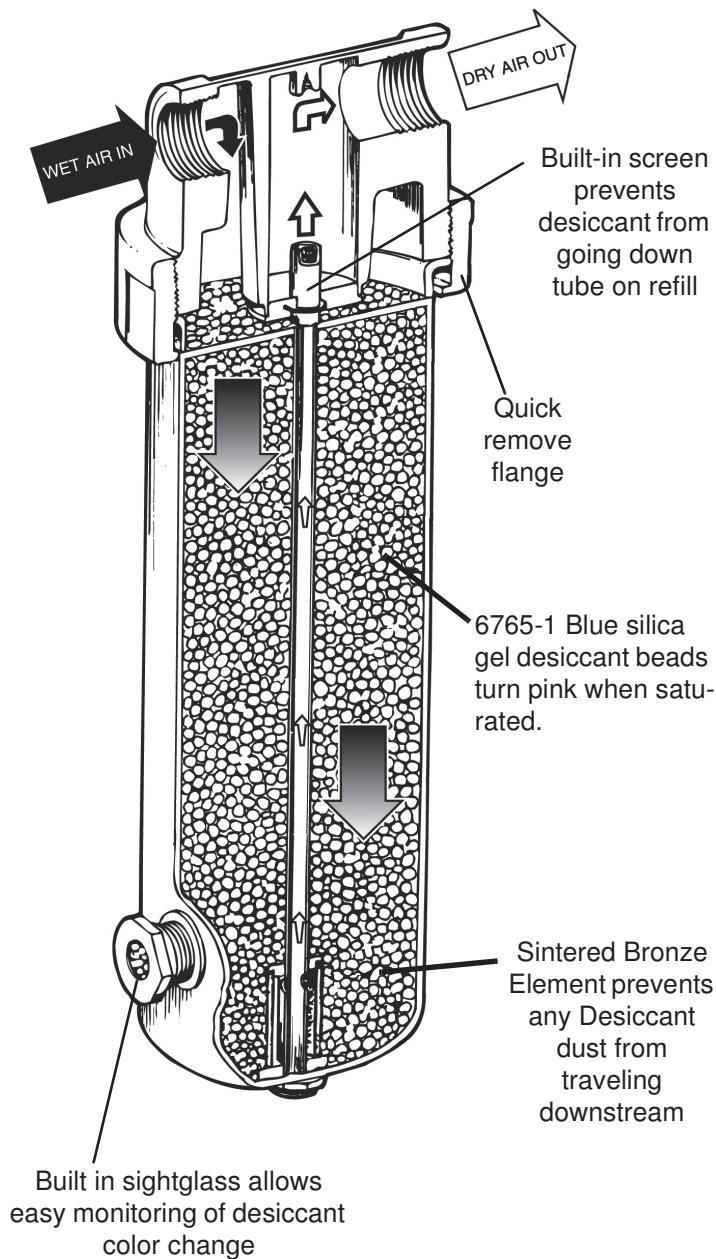

Desiccant Part No.	Color when fresh	Color when saturated
6765-1 Silica Gel (5 lb)	Blue	Pink
6765-4 Silica Gel (four 5 lb cans)	Blue	Pink

Sharpe's Desiccant System is a convenient and cost effective means of ensuring your refinish work is never exposed to damaging moisture. Compact in size, the Sharpe Desiccant System can be used almost anywhere.

Air Filter with Automatic Drain (Part No. 22601, Series B)

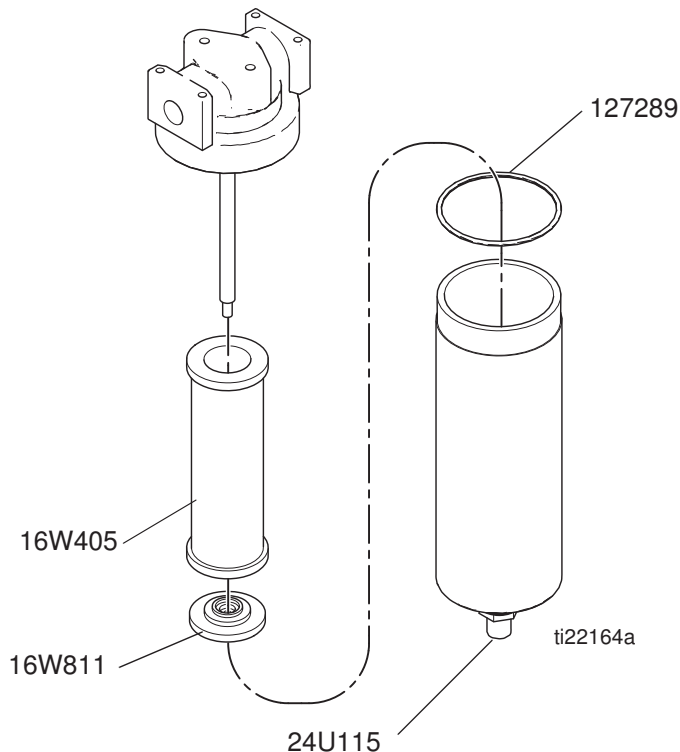

Maintenance

To maintain maximum filtering efficiency and to avoid excessive pressure drop, the filter must be kept clean. Bowl drainage is automatic with the float drain, however, manual draining can also be done by removing the bowl. A visible coating of dirt on the filter element surface or an excessive pressure drop is an indication that cleaning is necessary.

Cleaning

To clean, it is not necessary to remove the complete filter from the line. Disassembly is simple and does not require tools. Before disassembly, shut off the air supply and depressurize filter. Clean all parts with cleaning solvent and blow out filter body before reassembly. Wash filter element in cleaning solvent and blow out from the inside.

Automatic Drain

The automatic drain is equipped with a float actuated device which automatically ejects liquid contaminants under pressure.

Parts (Series B)

Part No.	Description
24U115	Automatic Drain
127289	O-Ring
16W811	Baffle End Cap
16W405	Filter Element

Coalescer with Automatic Drain (Part No. 22602, Series B)

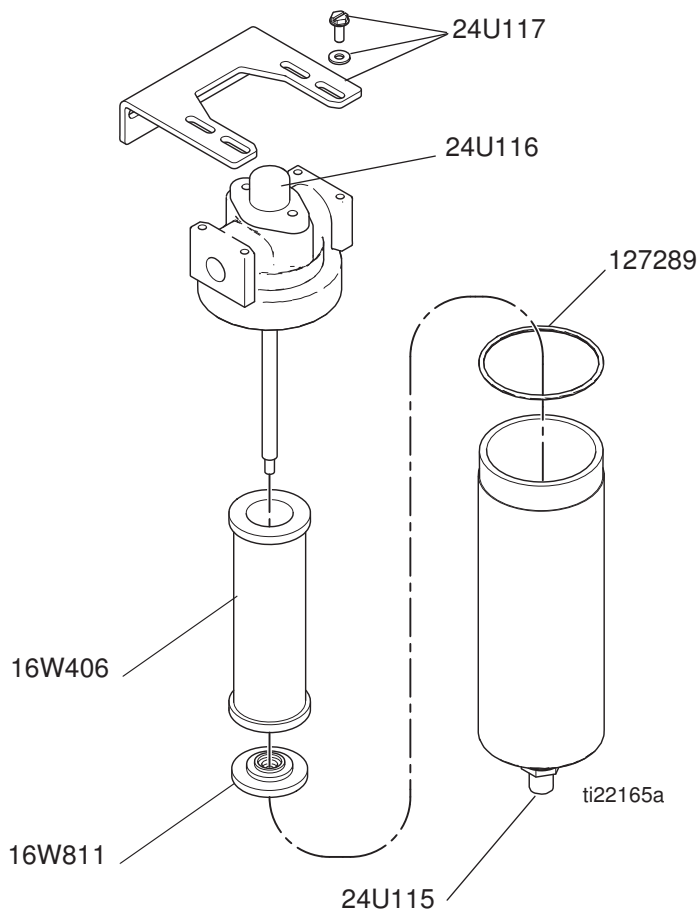

Installation

It is always recommended that a Sharpe air filter be installed upstream of the coalescing filter to remove 1 micron and larger size particles and separate large droplets of moisture from the air line.

Maintenance

To maintain maximum filtering efficiency and to avoid excessive pressure drop, the filter must be kept clean. Bowl drainage is automatic with the float drain. Remove the bowl to drain manually. A visible coating of dirt on the filter element surface or an excessive pressure drop is an indication that cleaning is necessary.

Cleaning

To clean, it is not necessary to remove the complete filter from the line. Disassembly is simple and does not require tools. Before disassembly, shut off the air supply and depressurize coalescer. Clean all parts with cleaning solvent and blow out body before reassembly. Replace coalescing element (part no. 16W406).

Pressure Drop Indicator

The differential pressure drop indicator on this unit is designed to provide early detection of a clogged coalescing filter element. As the filter element becomes clogged the red indicator will start to rise while air is flowing through the unit. When the pressure drop across the element reaches 10-12 psi (.07-.08 MPa, 0.7-0.8 bar) the red indicator will be in full view and the element should be replaced. Failure to replace the element when the pressure drop exceeds 10 psi (.07 MPa, 0.7 bar) will affect your air quality and tool efficiency.

Automatic Drain

The automatic drain is equipped with a float actuated device which automatically ejects liquid contaminants under pressure.

Parts (Series B)

Part No.	Description
24U115	Automatic Drain
24U117	Mounting Bracket Kit
16W811	Baffle End Cap
127289	O-Ring
24U116	Pop-up Indicator Repair Kit
16W406	1 Micron Coalescer Element

Desiccant Housing (Part No. 22603, Series B)

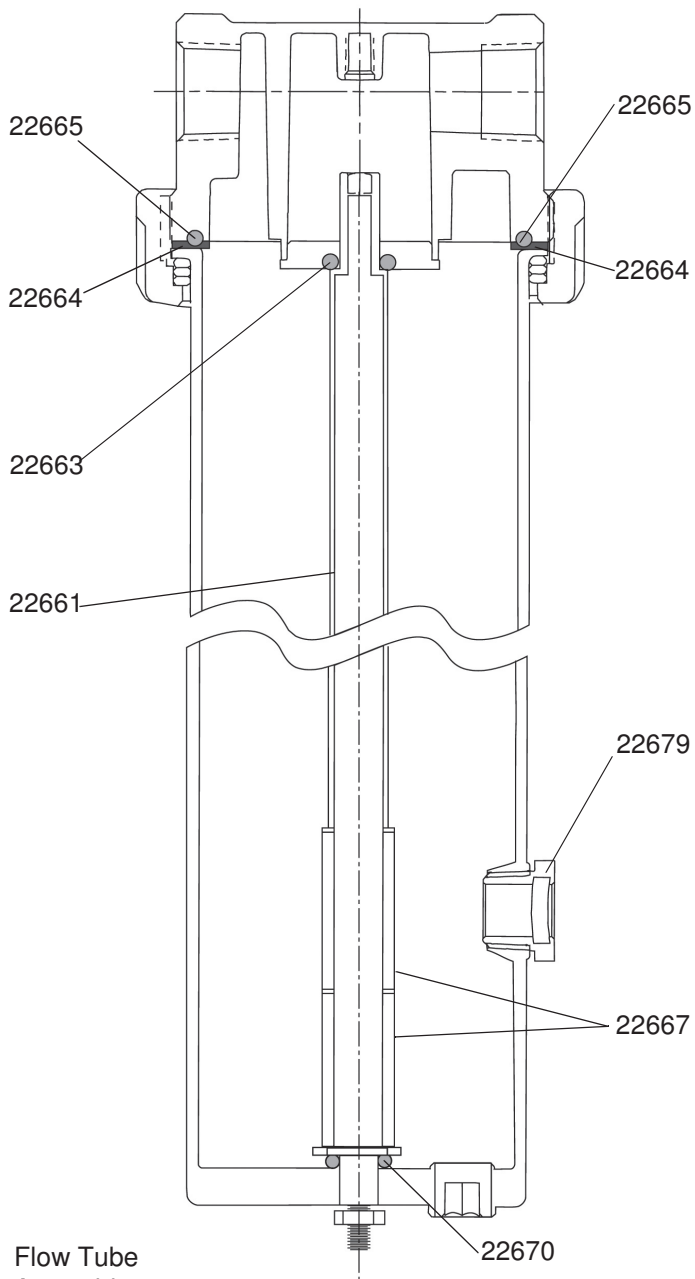

Flow Tube Assembly
(Includes: flow tube, nut, O-ring, filter elements and retainers)

Installation

Always place a moisture filter upstream to remove bulk fluids. Always place a coalescing filter upstream to remove oil. Desiccant coated with oil will not absorb moisture.

Maintenance

A supply of low flow/low humidity air will provide longer desiccant life; whereas, high flow/high humidity air will require more frequent desiccant changes.

Installed in an application with intermittent flow, Sharpe's desiccant dryer will typically dry air for weeks before silica gel desiccant requires replacement or regeneration.

Desiccant Changeout

Replace or regenerate the desiccant when the desiccant beads change color (see chart below), indicating the need for desiccant replacement. Simply remove the flange and bowl and replace with new desiccant or regenerate saturated desiccant by heating to 275°F (135°C) for 4 hours. To reorder, order desired part no. from the following chart.

Desiccant Part No.	Color when fresh	Color when saturated
6765-1 Silica Gel (5 lb)	Blue	Pink
288823 Silica Gel (four 5 lb cans)	Blue	Pink

Parts

Part No.	Description
6765-1	5 lb Desiccant
22661	Flow Tube Assy
22663	O-Ring
22664	Gasket
22665	O-Ring
22667	Filter Element (2)
22670	O-Ring
22679	Sight Glass

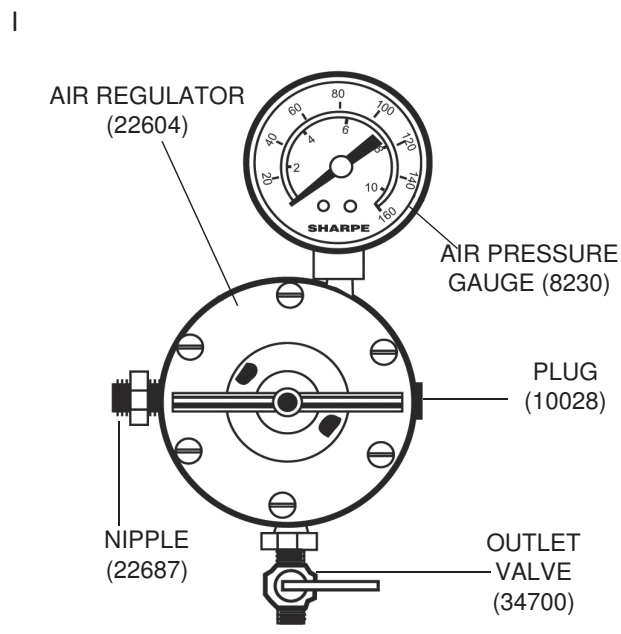
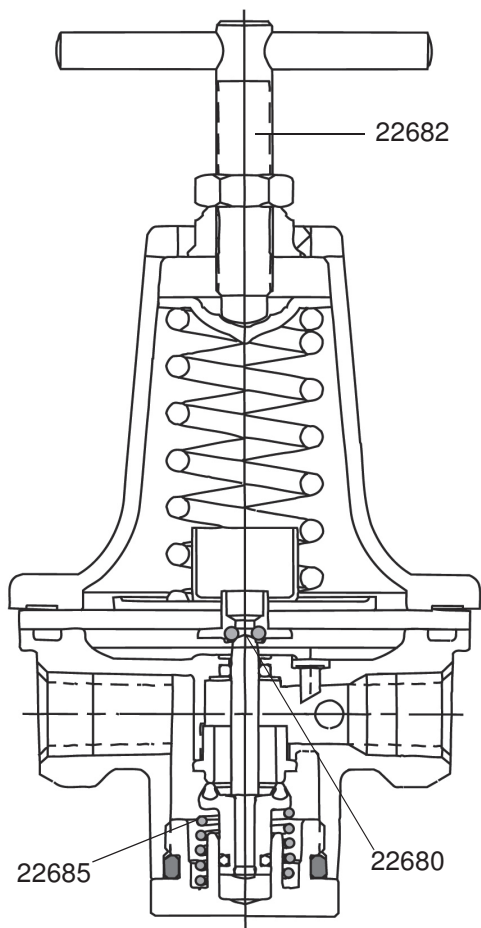

Self-Relieving Air Regulator (Part No. 22604)

Maintenance

If the air supply is kept clean, this regulator will provide long periods of uninterrupted service. Erratic regulator operation or loss of regulation is most always due to dirt in the diaphragm area and cleaning is in order.

Cleaning

Depressurize regulator, remove bottom plug, spring valve, and diaphragm. Clean parts with denatured alcohol, wipe off seat and blow out body with compressed air. Reassemble parts as a unit and screw into regulator before tightening bottom plug. Make sure disc is in center hole in body. Should regulator continue to malfunction, obtain diaphragm/valve repair kit (part no. 22680) and replace parts provided.

Specifications

- Air Inlet 3/8 in. F.P.T.
- Air Outlet 1/4 in. F.P.T. (3 EA.)
- Air Flow Capacity 100 cfm (2.8 m³/min.)
- Max. Operating Pressure 160 psi (1.1 MPa, 11 bar)
- Max. Temperature 150 °F (65 °C)

Parts

Part No.	Description
8230	Air Pressure Gauge
10028	Plug
22680	Diaphragm/Valve Repair Kit
22682	T-Handle Adjusting Screw
22685	Bottom Spring
22687	3/8 in. x 3/8 in. Nipple
34700	Outlet Valve

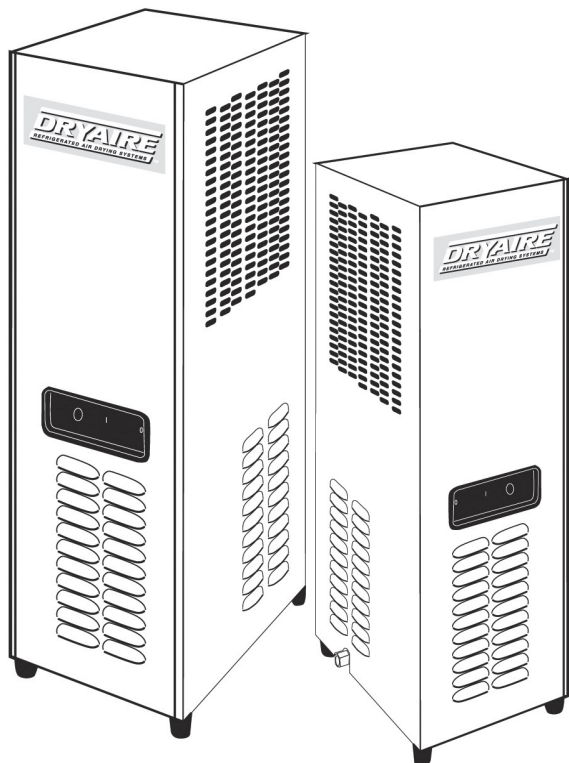

DRY AIRE

REFRIGERATED AIR DRYING SYSTEMS™

MODEL	USE WITH AIR COMPRESSOR SIZE	FLOW CAPACITY	POWER REQUIREMENTS	DIMENSIONS H" x W" x D"	WEIGHT (lbs)
6880	5.0-7.5 H.P.	25 CFM	115/1/60	28 x 10 x 13	80
6885	10 H.P.	35 CFM	115/1/60	28 x 10 x 13	81
6890	15 H.P.	50 CFM	115/1/60	37 x 17 x 17	150
6895	20 H.P.	75 CFM	115/1/60	37 x 17 x 17	150

REFRIGERATED AIR DRYERS

Cool, Dry, and Clean your compressed air supply in one, compact Easy-To-Use Package

DESIGNED AND BUILT TO RUN RELIABLY FOR YEARS

- Compact, high efficient heat exchangers
- Two stage separator/filter removes condensed oil and water
- Reliable air operated condensate drain automatically discharges water and oil from dryer without air loss

- Cools...** accepts high temperature air up to 180 °F (32 °C) directly from air compressor... no separate aftercooler or separator required
- Dries...** removes moisture... eliminates troublesome water from downstream air lines
- Cleans...** an integral 3 micron filter removes solid contaminants and oil aerosols

Clean, Dry Air

- Prevents surface blemishes and poor paint adhesion caused by compressed air humidity
- Ideal for autobody shops and industrial facilities with 5 to 15 horse-power compressors

Easy to Install

- Compact - saves valuable floor space
- No separate components to pipe together... simply connect inlet and outlet connection to the air system, plug in and it's ready to operate

Easy to Operate

- On/Off switch - turns all components on
- Fault light - indicates overload or system malfunction

Easy to Maintain

- Simple filter sleeve replacement
- Includes cleanable refrigeration condenser filter and inlet strainer

DRYWARE DESICCANT SYSTEM

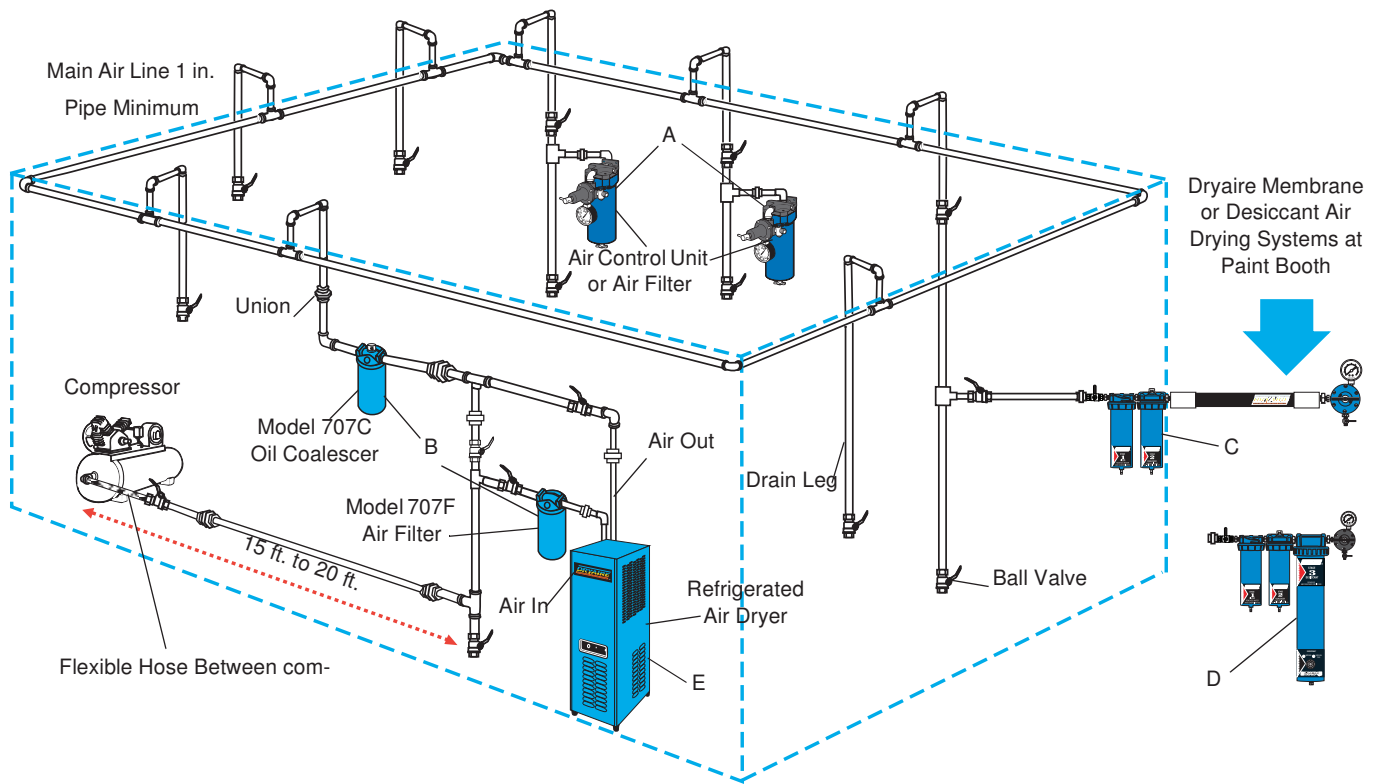

Ref. Letter	Description	Model No.
A	Sharpe 606	U06710
	Sharpe 606A	U06720
	Sharpe 606B	6730
	Sharpe 880A	6950
	Sharpe F88	8130
B	707C	6930
	707F	6920
	707FC	6910
C	Dryaire Membrane	6770
D	Dryaire Desiccant	6760
E	Refrigerated Air Dryer	
	25CFM	6880
	35CFM	6885
	50CFM	6890
	75CFM	6895

1 Year Limited Warranty

Sharpe warrants this product to the original user against defective material or workmanship for a period of 1 year from the date of purchase.

Sharpe reserves the right to determine whether the part or parts failed because of defective material, workmanship, or other causes. Failures caused by accident, alteration, or misuse are not covered by this warranty.

Sharpe, at its discretion, will repair or replace products covered under this warranty free of charge. Repairs or replacements of products covered under this warranty are warranted for the remainder of the original warranty period.

Sharpe or its authorized service representatives must perform all warranty repairs. Any repair to the product by unauthorized service representatives voids this warranty. The rights under this warranty are limited to the original user and may not be transferred to subsequent owners.

This warranty is in lieu of all other warranties, expressed or implied, including warranties of merchantability and fitness for a particular purpose. Some states do not allow the exclusion or limitations of incidental or consequential damages, so the above limitations may not apply to you.

Sharpe Information

TO PLACE AN ORDER, contact your SHARPE distributor or call 1-800-742-7731 or visit our website at www.sharpe1.com.

Product Registration

Thank you for the purchase of your Sharpe® product. We greatly appreciate your business.

Important reasons to register your product:

- Registration enables Sharpe to notify you if there is a problem with your product.
- Improved Product Development - Your input helps us continue to design products that meet your needs.

For the most up-to-date information and to register your product, please go to www.sharpe1.com and click on "Register Product."

All written and visual data contained in this document reflects the latest product information available at the time of publication. Graco reserves the right to make changes at any time without notice.

Original instructions. This manual contains English. MM 310595

SHARPE MANUFACTURING • P.O. BOX 1441, MINNEAPOLIS, MN 55440-1441

1-800-742-7731, www.sharpe1.com
310595L, 10/2003, Revised 2/2014