

## 880A AIR CONTROL UNIT

PART NO. 6950

Maximum Working Pressure: 160 psi (1.1 MPa, 11.0 bar)

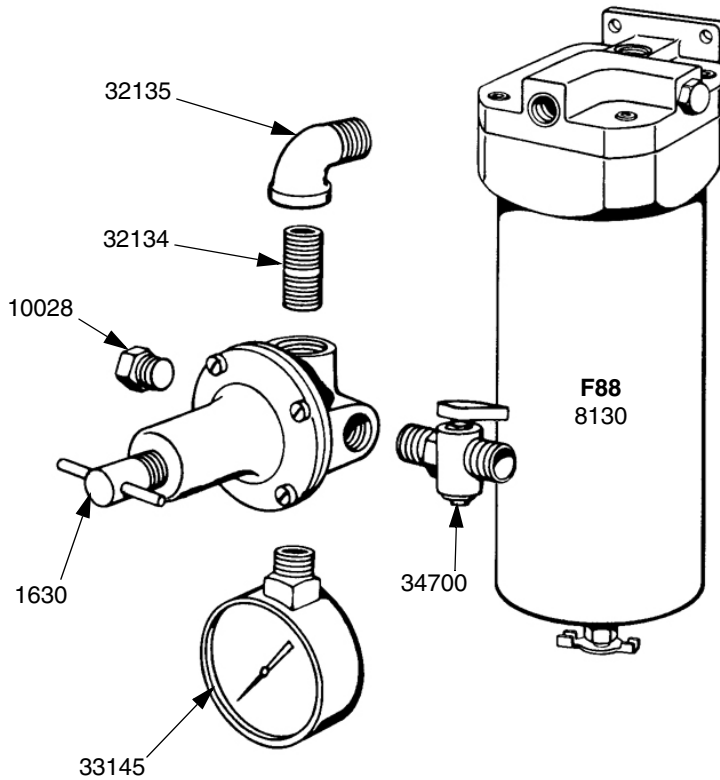

PART NO.	DESCRIPTION
1630	Air Regulator
8130	Air Filter
10028	Plug
32134	Nipple
32135	Elbow
33145	Gauge
34700	Air Cock

## 18C-3R AIR REGULATOR

PART NO. 1630

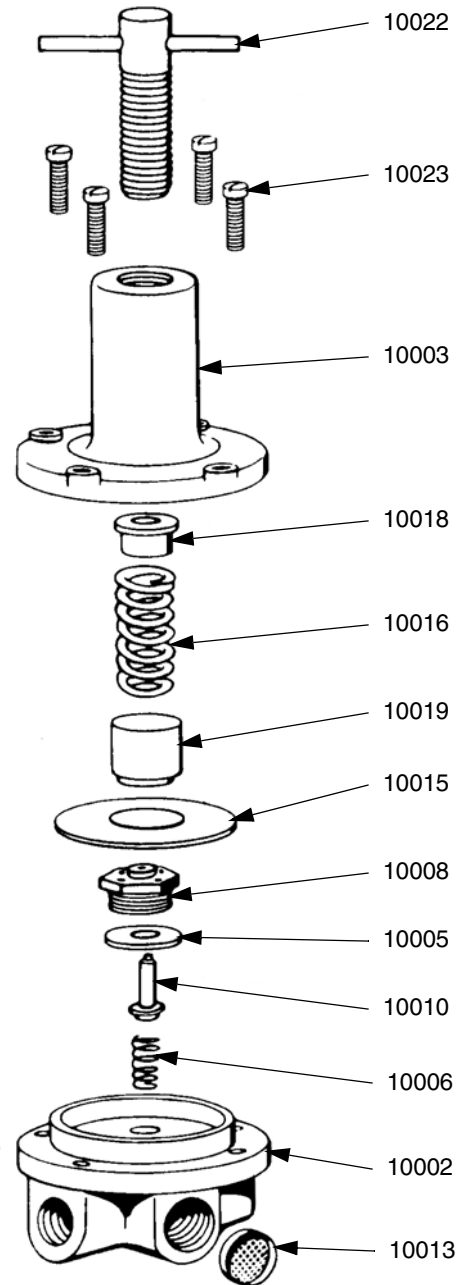

PART NO.	DESCRIPTION
10022	Adjusting Screw
10023	Screw
10003	Bonnet
10018	Washer Spring
10016	Pressure Spring
10019	Vibration Dampener
10015	Diaphragm
10008	Valve Body
10005	Valve Seat
10010	Valve
10006	Valve Spring
10002	Body
10013	Brass Screen

# F88 AIR FILTER

PART NO. 8130

Maximum Working Pressure: 160 psi (1.1 MPa, 11.0 bar)

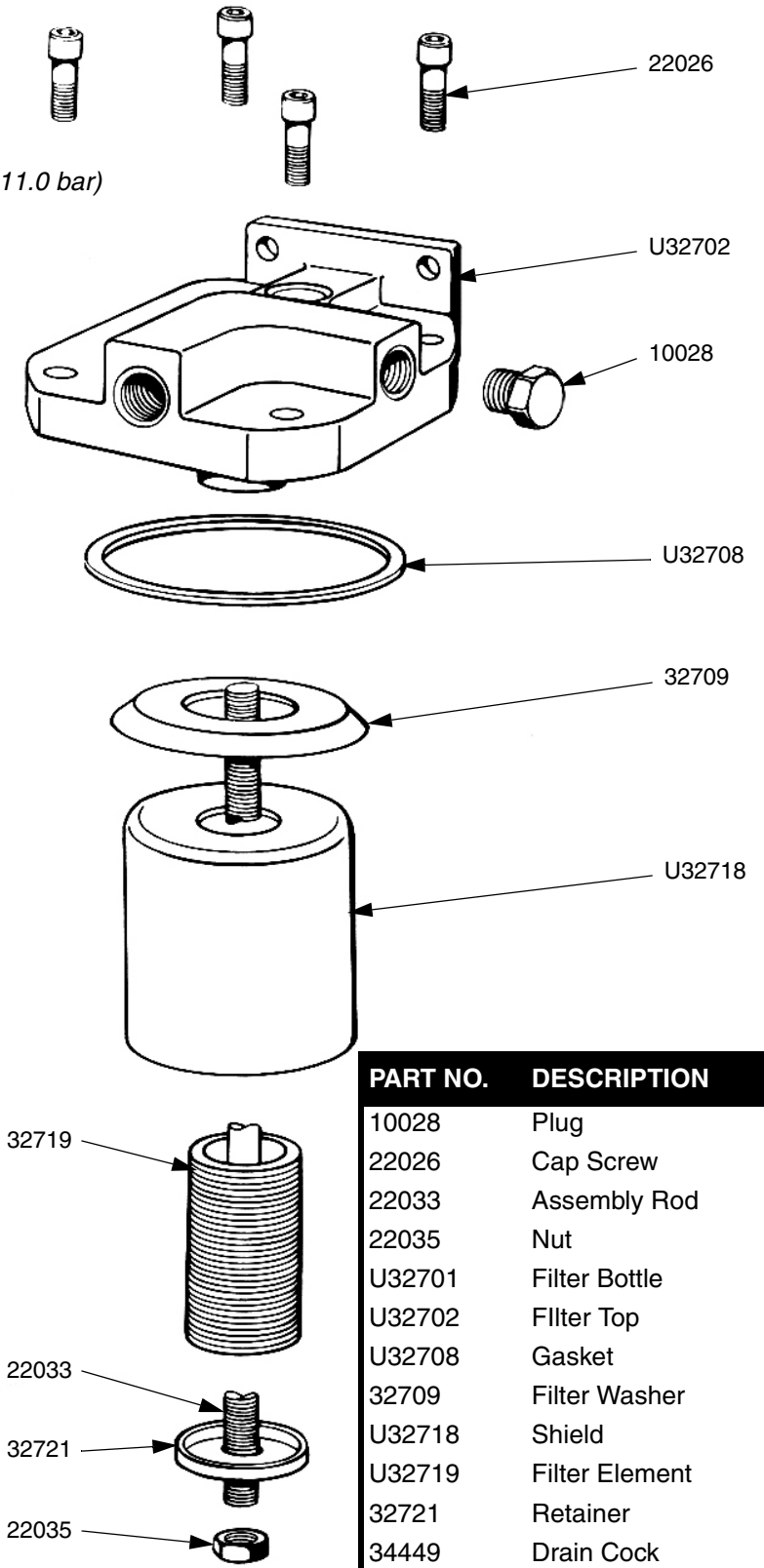
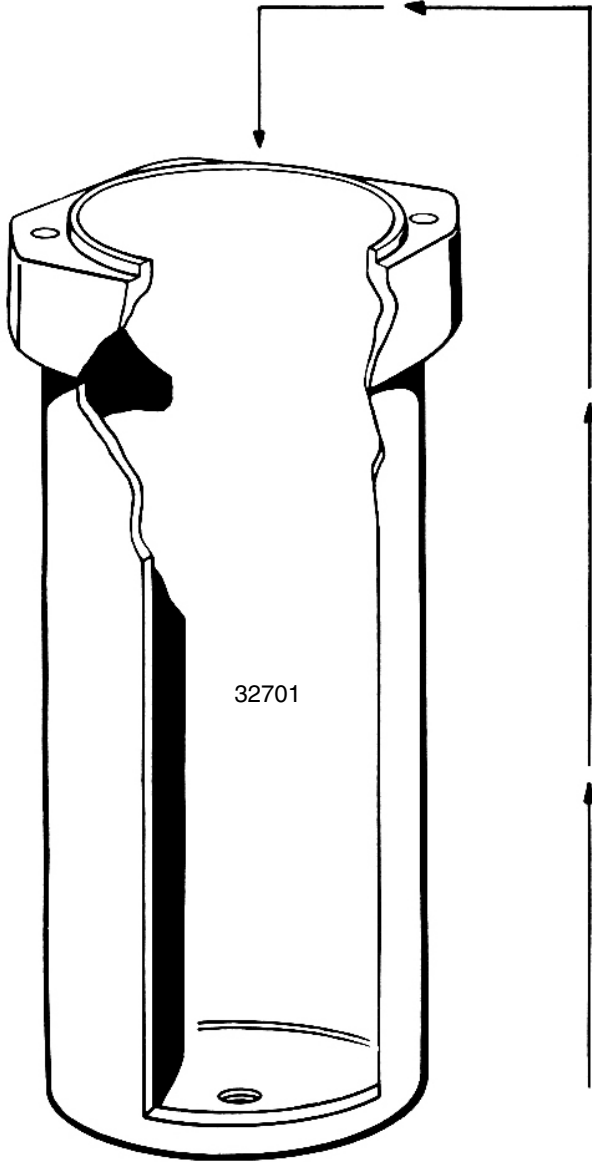

PART NO.	DESCRIPTION
10028	Plug
22026	Cap Screw
22033	Assembly Rod
22035	Nut
U32701	Filter Bottle
U32702	Filter Top
U32708	Gasket
32709	Filter Washer
U32718	Shield
U32719	Filter Element
32721	Retainer
34449	Drain Cock