

Cobalt

HVLP Gravity Feed Spray Gun

Compliant Gravity Feed Spray Gun

SHARPE

THE SPRAY GUN PEOPLE
 FOR PRODUCT INFORMATION CALL:
1-800-742-7731



Important Safety Instructions

Read all warnings and instructions in this manual.
 Save these instructions.

Maximum Air Inlet Pressure: 100 psi (0.7 MPa, 7 bar)
 Maximum HVLP Compliant Air Pressure: see table below

Includes Cobalt Gravity Feed HVLP or Compliant Spray Gun and 650GC Aluminum Gravity Cup



Gun Part No.	Needle/Nozzle Size (mm)	Air Consumption (CFM)	Maximum HVLP Air Pressure psi (kPa, bar)	Recommended Usage
HVLP Gravity Feed Gun				
5812L	1.2	13.9*	50 (345, 3.4)	Topcoat, high solids, colors and clears
5814L	1.4	13.9*	50 (345, 3.4)	Topcoat, high solids, colors and clears
5816L	1.6	13.9*	50 (345, 3.4)	Topcoat, medium solids, colors and clears
5815L	1.5	12.5*	40 (276, 2.8)	Primer, high solids, sealers
5818L	1.8	12.5*	40 (276, 2.8)	Primer, general purpose
5823L	2.3	12.5*	30 (207, 2.1)	Primer, high viscosity
Compliant Gravity Feed Gun				
5712	1.2	13.8†		Topcoat, high solids, colors and clears
5714	1.4	13.8†		Topcoat, high solids, colors and clears
5716	1.6	13.8†		Topcoat, medium solids, colors and clears

* At HVLP compliant air pressure





† At 50 psi (345 kPa, 3.4 bar) air inlet pressure

SHARPE MANUFACTURING COMPANY • P.O. BOX 1441, MINNEAPOLIS, MN 55440-1441

1-800-742-7731, www.sharpe1.com

309999G, 7/2007

 **WARNING**

	<p>FIRE AND EXPLOSION HAZARD</p> <p>Flammable fumes, such as solvent and paint fumes, in work area can ignite or explode. To help prevent fire and explosion:</p> <ul style="list-style-type: none"> • Use equipment only in well ventilated area. • Eliminate all ignition sources; such as pilot lights, cigarettes, portable electric lamps, and plastic drop cloths (potential static arc). • Keep work area free of debris, including solvent, rags and gasoline. • Do not plug or unplug power cords or turn lights on or off when flammable fumes are present. • Ground equipment and conductive objects in work area. • If there is static sparking or you feel a shock, stop operation immediately. Do not use equipment until you identify and correct the problem.
	<p>EQUIPMENT MISUSE HAZARD</p> <p>Misuse can cause death or serious injury.</p> <ul style="list-style-type: none"> • Do not exceed the maximum working pressure or temperature rating of the lowest rated system component. See Technical Data in all equipment manuals. • Use fluids and solvents that are compatible with equipment wetted parts. See Technical Data in all equipment manuals. Read fluid and solvent manufacturer's warnings. • Check equipment daily. Repair or replace worn or damaged parts immediately. • Do not alter or modify equipment. • Use equipment only for its intended purpose. Call your Graco distributor for information. • Route hoses and cables away from traffic areas, sharp edges, moving parts, and hot surfaces. • Do not use hoses to pull equipment. • Keep children and animals away from work area. • Comply with all applicable safety regulations.
	<p>TOXIC FLUID OR FUMES HAZARD</p> <p>Toxic fluids or fumes can cause serious injury or death if splashed in the eyes or on skin, inhaled, or swallowed.</p> <ul style="list-style-type: none"> • Read MSDS's to know the specific hazards of the fluids you are using. • Store hazardous fluid in approved containers, and dispose of it according to applicable guidelines.
	<p>PERSONAL PROTECTIVE EQUIPMENT</p> <p>You must wear appropriate protective equipment when operating, servicing, or when in the operating area of the equipment to help protect you from serious injury, including eye injury, inhalation of toxic fumes, burns, and hearing loss. This equipment includes but is not limited to:</p> <ul style="list-style-type: none"> • Protective eyewear • Clothing and respirator as recommended by the fluid and solvent manufacturer • Gloves • Hearing protection
	<p>PRESSURIZED EQUIPMENT HAZARD</p> <p>Fluid from the gun/dispense valve, leaks, or ruptured components can splash in the eyes or on skin and cause serious injury.</p> <ul style="list-style-type: none"> • Follow Pressure Relief Procedure in this manual, when you stop spraying and before cleaning, checking, or servicing equipment. • Tighten all fluid connections before operating the equipment. • Check hoses, tubes, and couplings daily. Replace worn or damaged parts immediately.

2 Year Limited Warranty

Sharpe warrants this product to the original user against defective material or workmanship for a period of 1 year from the date of purchase.

Sharpe reserves the right to determine whether the part or parts failed because of defective material, workmanship, or other causes. Failures caused by accident, alteration, or misuse are not covered by this warranty.

Sharpe, at its discretion, will repair or replace products covered under this warranty free of charge. Repairs or replacements of products covered under this warranty are warranted for the remainder of the original warranty period.

Sharpe or its authorized service representatives must perform all warranty repairs. Any repair to the product by unauthorized service representatives voids this warranty. The rights under this warranty are limited to the original user and may not be transferred to subsequent owners.

This warranty is in lieu of all other warranties, expressed or implied, including warranties of merchantability and fitness for a particular purpose. Some states do not allow the exclusion or limitations of incidental or consequential damages, so the above limitations may not apply to you.

COBALT GRAVITY FEED SPRAY GUN

Setup

- Check that your shop air provides adequate air flow.
 - Use a minimum 3/8 in. ID air supply hose.
 - Set shop air pressure regulator (not supplied) according to paint manufacturer's recommendation. See maximum pressures and compliant air pressures on cover.
 - Make sure no air restrictions, such as low-volume cheater-valves, obstruct the air flow. If an air adjusting valve is desired, use a SHARPE Air Adjusting Valve 24AAV (part no. 2210), 36AAV-HOV (part no. 3310) or HOV (part no. U04410).
 - Install a shutoff valve (not supplied) downstream of the air regulator to shut off gun air.
 - Install an inline air filter (not supplied) to clean and dry the air supply to the gun.
1. Make sure air supply is turned off.
 2. Connect a clean, dry, filtered air supply to the gun air inlet (9).
 3. If this is first time using the equipment, flush the spray gun.

Operation

Pressure Relief Procedure

⚠ WARNING



Follow **Pressure Relief Procedure** when you stop spraying and before cleaning, checking, or servicing equipment. Read warnings, page 2.

1. Turn off gun air supply.
2. Trigger the gun to relieve pressure.

Flushing

⚠ WARNING



Read warnings, page 2.

Flush before using the equipment, before changing colors, and when you are done spraying. Use solvent that is compatible with gun wetted parts and fluid that will be sprayed. Flush at lowest possible pressure.

 Refer to **Compliant Cleaning Methods**, page 4, to comply with air quality laws if applicable.

1. Follow **Pressure Relief Procedure**.
2. Dispose of any paint in cup.
3. Fill cup with small amount of solvent.
4. Spray into grounded metal waste container until equipment is clean.
5. Follow **Pressure Relief Procedure**.

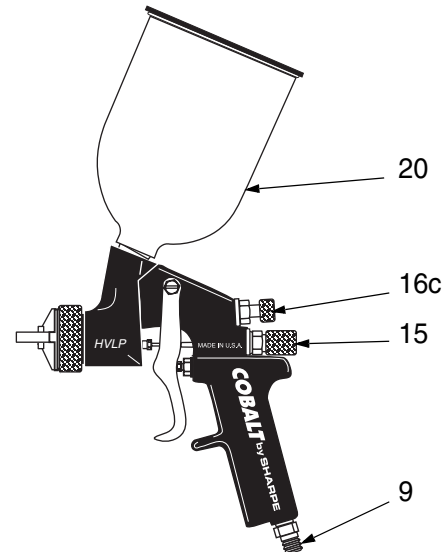

FIG. 1

Spraying

CAUTION

Excessive atomizing air pressure can increase over-spray, reduce transfer efficiency, result in a poor quality finish from dry spray.

Regulatory agencies in certain states prohibit the operation of a spray gun above 10 psi (69 kPa, .7 bar) atomizing air cap pressure.

1. Fill cup (20) with material. Do not fill past full markings on cup.
2. Turn on shop air to gun and set atomizing pressure with the gun fully triggered.
3. Adjust the pattern size and shape with the spray width adjustment knob (16c). Turn knob clockwise to reduce pattern size and counterclockwise to increase it.



See **Troubleshooting** guide if you experience an irregular pattern.

4. Fluid control knob (15) is factory set for maximum needle trigger travel and material flow. To decrease needle/trigger travel and decrease fluid flow, turn the knob clockwise.

Cleaning and Maintenance

WARNING



Follow **Pressure Relief Procedure** when you stop spraying and before cleaning, checking, or servicing equipment. Read warnings, page 2.

CAUTION

- Do not submerge gun in solvent. Solvent dissolves lubricant, dries out packings, and may clog air passages.
- Do not use metal tools to clean air cap holes as this may scratch them and distort the spray pattern.
- Use a compatible solvent.
- Gun and cup can be cleaned in a gun washer.



Clean air line filters as directed by the manufacturer.

Volatile Organic Compounds (VOC) Regulation

In certain states, spraying solvents that release VOC's into the atmosphere when cleaning a spray gun is prohibited. To comply with these air quality laws you must use a cleaning method that prevents the escape of VOC vapors into the atmosphere. See **Compliant Cleaning Methods** below.

Compliant Cleaning Methods

- Place spray gun in a gun washer that completely encloses the gun and components during cleaning, rinsing, and draining.
- Spray solvent through the spray gun into a closed gun cleaning station.

Cleaning Gun and Cup



Refer to **Compliant Cleaning Methods** to comply with air quality laws if applicable.

1. Follow **Flushing** procedure, page 3.
2. Use a rag moistened in solvent to wipe outside of gun and cup.
3. Make sure cup lid vent hole is clear.

4. Blow dry gun inside and out. Lubricate gun as described in **Spray Gun Maintenance**.

Cleaning Nozzle and Air Cap

CAUTION

- Trigger gun and use nozzle removal tool 41160 whenever you tighten or remove nozzle to avoid damaging needle seat and nozzle.
- Do not use metal tools to clean air cap holes as this may scratch them and distort the spray pattern.

To clean the air cap and nozzle, remove and soak them in a compatible cleaning solution. Clean them and front of gun with a soft-bristle brush dipped into compatible solvent. Do not use a wire brush or metal tools. To clean out air cap holes, use a soft implement, such as a toothpick.

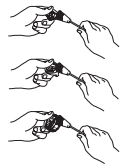

Spray Gun Maintenance

- Frequently lubricate the gun moving parts with a drop of non-silicone oil (part no. 8255). See FIG. 2.
- Do not disassemble the spray gun if you are having a spray pattern problem. Check **Troubleshooting**, page 5, for information on how to correct the problem.
- Check for fluid leakage. Tighten fittings or replace equipment as needed.

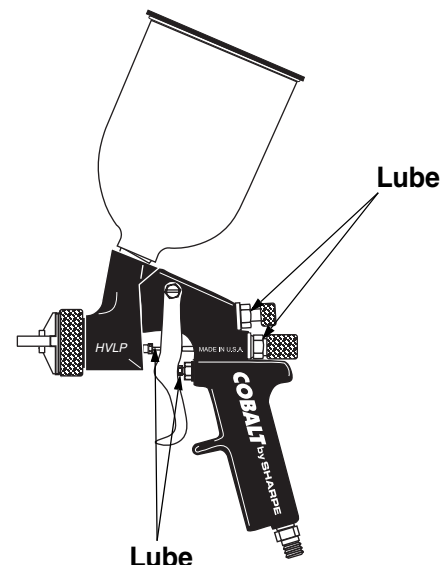

FIG. 2

COBALT GRAVITY FEED SPRAY GUN





Troubleshooting



WARNING



Follow **Pressure Relief Procedure**, page 3, before troubleshooting or servicing. Read warnings, page 2.

Problem	Cause	Solution
 Right	Normal pattern	No action necessary
 Wrong Heavy top or bottom pattern	Dirty or damaged air cap or fluid nozzle.	Rotate air cap 180°. <i>If pattern follows air cap</i> , problem is in air cap. Clean and inspect. See page 4. If pattern is not corrected, replace air cap. <i>If pattern does not follow the air cap</i> , the problem is with the fluid nozzle. Clean and inspect the nozzle. See page 4. If the pattern is not corrected, replace nozzle.
 Wrong Split pattern	Pressure too high for viscosity of material being sprayed.	a. Reduce air pressure. b. Increase material viscosity c. Correct pattern by narrowing fan size with spray width adjustment knob.
 Wrong	Dirty or distorted air horn holes.	Rotate air cap 180°. <i>If pattern follows air cap</i> , problem is in air cap. Clean and inspect. See page 4. If pattern is not corrected, replace air cap.
Gun spitting	Air getting into paint stream	<ul style="list-style-type: none"> • Check if cup is empty and fill. • Tighten fluid nozzle. • Check and tighten fluid needle packing nut. • Check fluid nozzle seat for damage.
Will not spray.	a. Cup is empty b. Fluid adjustment knob (15) turned too far clockwise.	a. Fill cup. b. Adjust knob (15) to the counterclockwise.
Excessive air blowing back	a. Loose fluid nozzle. b. Damaged fluid nozzle seat.	a. Tighten fluid nozzle. b. Replace seat.

COBALT GRAVITY FEED SPRAY GUN

Gun Part No.	Needle/Nozzle Size (mm)	Air Cap Part No.	Needle/Nozzle Set Part No.
HVLP Gravity Feed Gun			
5812L	1.2	28012	118534
5814L	1.4	28012	118536
5815L	1.5	28015	118649
5816L	1.6	28012	118535
5818L	1.8	28015	118537
5823L	2.3	28015	118650
Compliant Gravity Feed Gun			
5712	1.2	28018	118534
5714	1.4	28018	118536
5716	1.6	28018	118535

Ref. No.	Part No.	Description	Qty.
1	28127	Gun Handle, <i>HVLP only</i>	1
	28128	Gun Handle, <i>Compliant only</i>	1
2	26016	Air Valve Assembly; Includes items 2a-2d	1
2a*	26032	• Packing Nut	1
2b*	25066	• Air Valve	1
2c	16151	• Housing	1
2d*	16162	• Packing	1
3*	10333	Trigger Screw	1
4*	16163	Gasket	1
6	26042	Trigger	1
7*	26044	Trigger Shaft	1
8	26054	Pipe Plug	1

Ref. No.	Part No.	Description	Qty.
9	9993	Air Inlet Fitting	1
10	26056	Width Control Valve	1
11	118524	Pressure Limit Bushing; <i>HVLP Guns only</i>	1
12	see table	Needle/Nozzle Set	1
13*	16150	Needle Spring	1
14*	10326	Gasket	1
15	25092	Fluid Control Knob	1
16	26018	Width Control Assembly; Includes item 16a-16c	1
16a*	16175	• Retaining Ring	1
16b	38120	• O-Ring	1
16c	26066	• Body	1
17	26065	Control Valve/Knob	1
18	41137	Screw, 7/16-27 UNS	1
19	see table	Air Cap	1
20	6685	Gravity Cup; Includes items 20a-20e	1
20a	22002	• Lid Assembly; Includes items 20b-20c	1
20b	22001	- Lid Only	1
20c	22178	- "No Drip" Assembly	1
20d	22107	• Gasket	1
20e	21719	• Filter	1
32	16100	Nozzle Gasket	1
33	118643	Gun Head	1
34	34941	Seal	1
35*	26022	Fluid Needle Packing	1
36	26032	Packing Nut	1

* Parts included in Repair Kit 28140

Gun Accessory Tools

Part No. 41160: 1/2 in. Nozzle Removal Tool

Part No. 41150: Nozzle Cleaning Brush

Technical Data

Maximum Air Inlet Pressure: 100 psi (0.7 MPa, 7 bar)

Maximum HVLP Compliant Air Pressure: see front cover
(delivers 10 psi (69 kPa, 0.7 bar) spraying pressure at air cap)

Air Consumption: see table on cover

Air Inlet: 1/4 (R1/4-19) npsm

Weight: 1 lb. 8 oz. (0.68 kg)

Gravity Cup Size: 22 oz. (650 cc) cup

Wetted Parts: stainless steel, carbon steel, aluminum, brass,
low density polyethylene

COBALT GRAVITY FEED SPRAY GUN

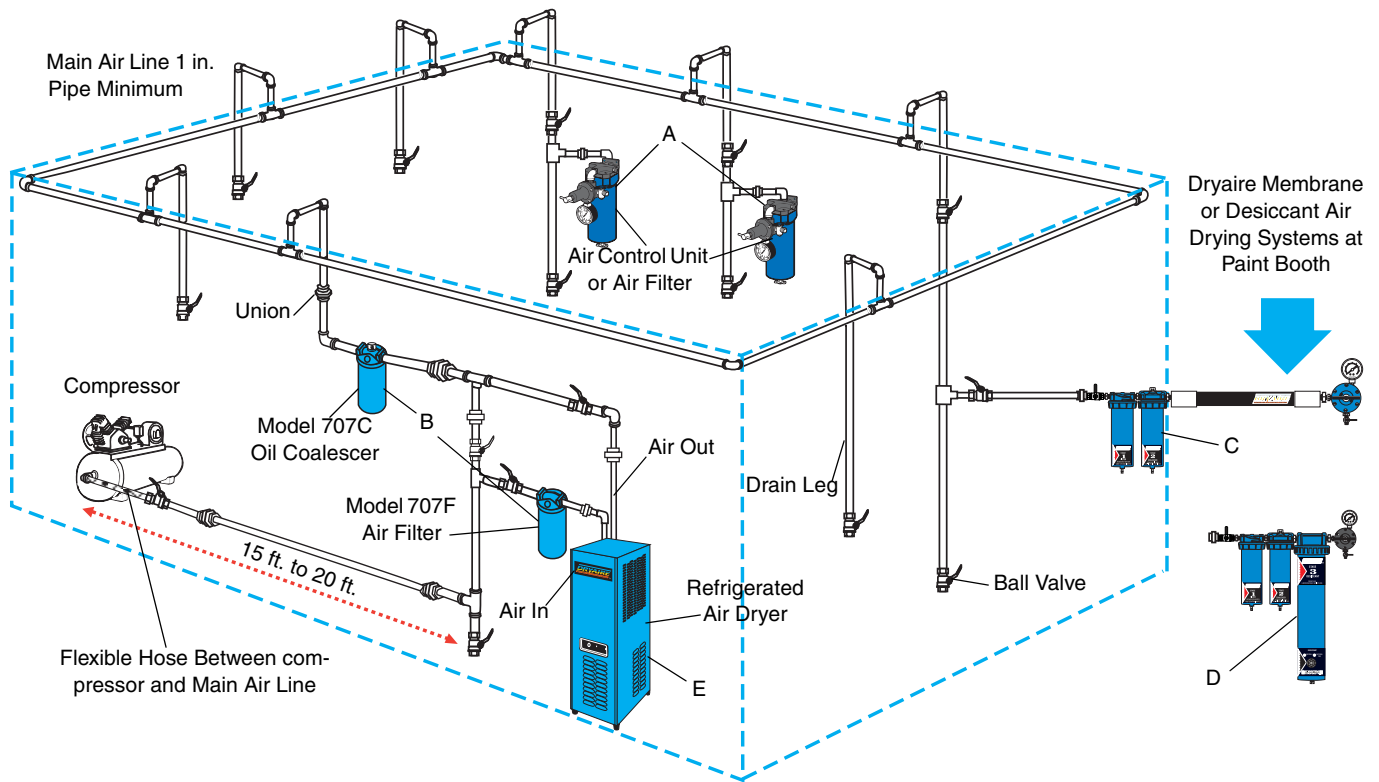

Ref. Letter	Description	Model No.
A	Sharpe 606	U06710
	Sharpe 606A	U06720
	Sharpe 606B	6730
	Sharpe 880A	6950
	Sharpe F88	8130
B	707C	6930
	707F	6920
	707FC	6910
C	Dryaire Membrane	6770
D	Dryaire Desiccant	6760
E	Refrigerated Air Dryer	
	25CFM	6880
	35CFM	6885
	50CFM	6890
	75CFM	6895