

Dryaire Membrane Air Drying System

310596H

EN

Model 6770, Series C

*Maximum Working Pressure: 175 psi
(1.2 MPa, 12 bar)*



Important Safety Instructions

Read all warnings and instructions in this manual. Save these instructions.

System Includes:

- Air Filter w/Overnight Drain (Part No. 22601)
- Coalescer w/Overnight Drain (Part No. 22605)
- Air Regulator Assembly (Part No. 22604)
- Membrane Air Dryer (Part No. 1-6770-3)

System Description

Sharpe's DRYAIRE Membrane Air Drying System is the painter's insurance for removing dirt, water, oil, and uncondensed moisture from compressed air lines. It provides clean dry compressed air while reducing overall costs and minimizing waste.

Sharpe's 3-Stage Point-of-Use System comes assembled and is simple to install.

Approved for Paint Company warranty programs when applying today's state-of-the-art refinish materials.

Ideal for protecting moisture sensitive tools.

Advanced Membrane Technology

- Point-of-Use air dryer
- Optimize overall drying costs
- Effective even at low flow rates
- No chemicals to dispose of
- Transparent operation
- Continuous, effective air drying
- No maintenance on Stage 3
- No electricity
- No additional hookups or connections
- Easy installation

Model 6770 Membrane Air Drying System

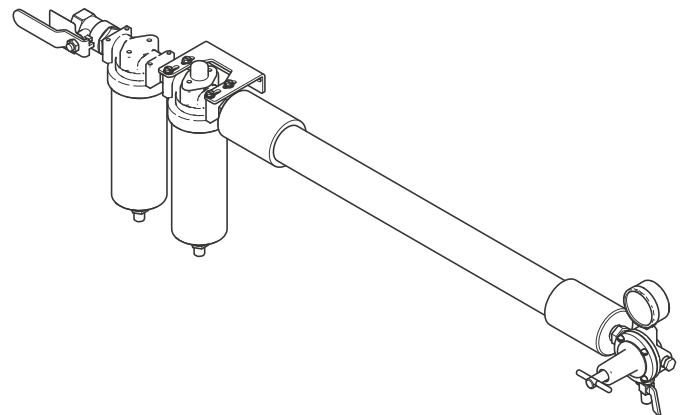

ti22159a

Specifications

STAGE 1: Air Filter w/Overnight Drain (Part No. 22601, Series B)

Provides removal of water and contaminants down to 3 microns.

Air Inlet 1/2 in. F.P.T.

Air Outlet 1/2 in. F.P.T.

Air Flow Capacity 100 cfm (3.2 m³/min.) at 100 psi (0.7 MPa, 7 bar)

Max. Operating Pressure 175 psi (1.2 MPa, 12 bar)

Max. Temperature 150°F (65°C)

STAGE 2: Coalescer w/Overnight Drain (Part No. 22605, Series B)

Provides removal of oil and sub-micronic particles down to .01 microns.

Air Inlet 1/2 in. F.P.T.

Air Outlet 1/2 in. F.P.T.

Air Flow Capacity 50 cfm (2.0 m³/min.) at 100 psi (0.7 MPa, 7 bar)

Max. Operating Pressure 175 psi (1.2 MPa, 12 bar)

Max. Temperature 150°F (65°C)

STAGE 3: Membrane Air Dryer (Part No. 1-6770-3)

Provides removal of uncondensed moisture.

Air Inlet 1/2 in. F.P.T.

Air Outlet 1/2 in. F.P.T.

Air Flow Capacity 30 cfm (0.85m³/min.)

Max. Operating Pressure 175 psi (1.2 MPa, 12 bar)

Max. Temperature 175°F (79°C)

Warning



Relieve the pressure when you stop spraying and before cleaning, checking, or servicing equipment.

Installation

1. Install Air Drying System as close as possible to the point where the air is being used.
2. Install main shut-off valve (part no. 22695) upstream of air system to allow maintenance of the unit.
3. Install system with air flow through filters in the direction noted on top of units.
4. Minimum 1/2 in. npt piping is recommended. Avoid using many fittings, couplings, etc. that restrict air flow.
5. Maximum operating pressure and operating temperature of system is: 160 psi (1.1 MPa, 11 bar) and 150°F (65°C).

Operation

After the system is installed and ready to use:

1. Attach air hose(s) to outlet valve (part no. 34700).
2. Open main shut-off valve upstream of system.
3. Adjust regulator to desired setting by turning T-handle adjusting screw in or out.
4. Open outlet valve (part no. 34700) to supply air to spray guns or tool being used.
5. With air flowing, readjust air pressure at regulator if necessary.
6. Be sure to turn off unit when not in use.

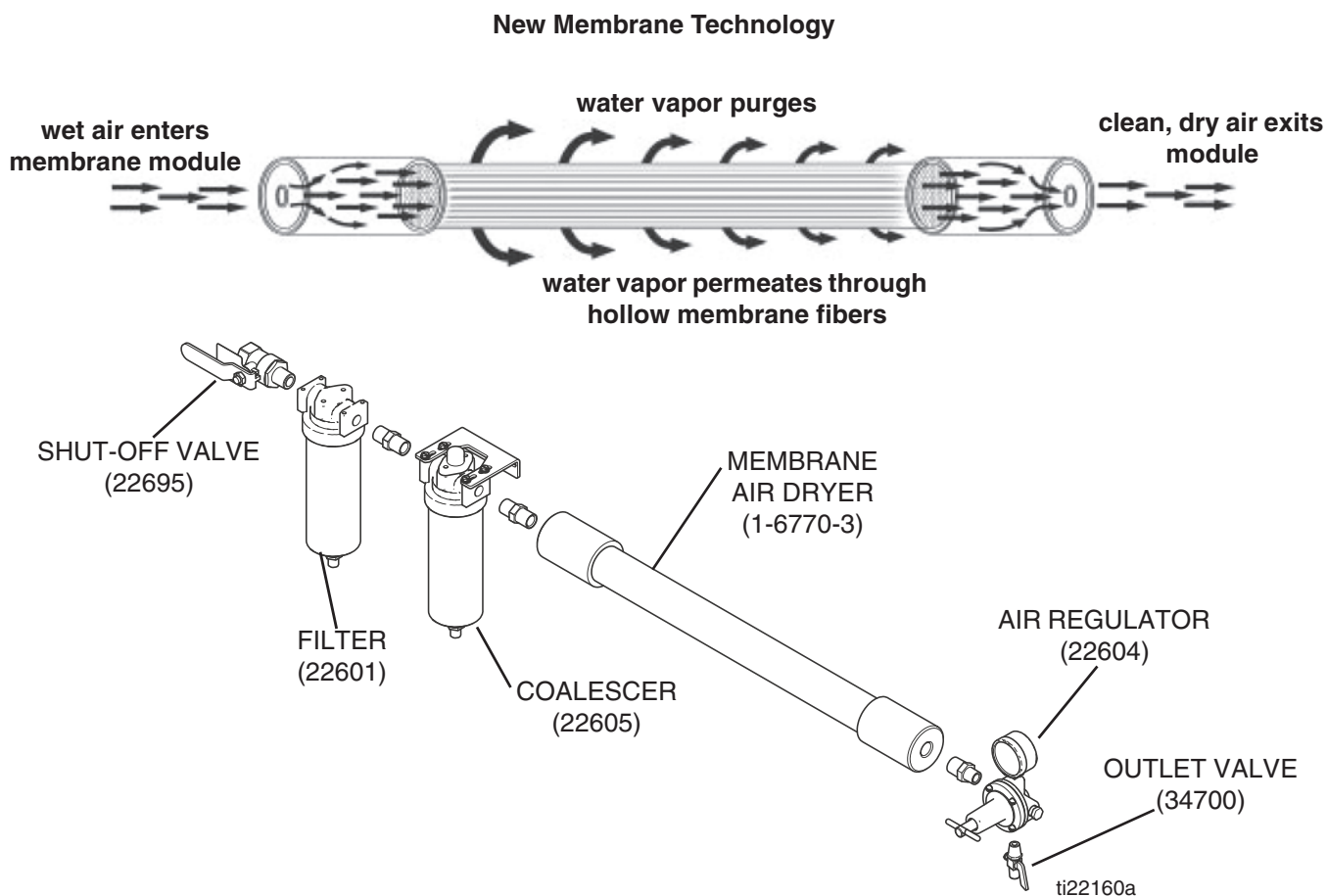

Maintenance

1. Check system at least once per shift to ensure proper drainage.
2. Before performing maintenance on system, close main shut-off valve located upstream. Bleed off residual air in system.

Air Filter w/Automatic Drain (Part No. 22601, Series B)

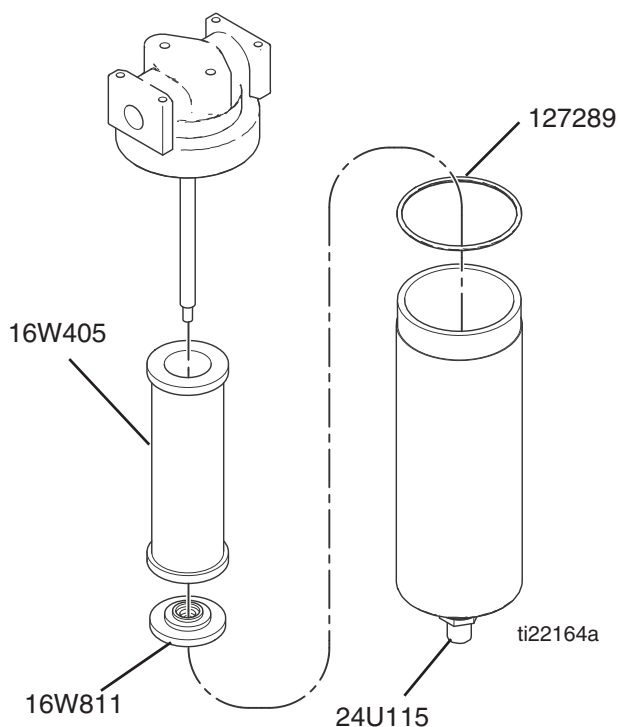

Maintenance

To maintain maximum filtering efficiency and to avoid excessive pressure drop, the filter must be kept clean. Bowl drainage is automatic with the float drain. Remove the bowl to drain manually. A visible coating of dirt on the filter element surface or an excessive pressure drop is an indication that cleaning is necessary.

Cleaning

To clean, it is not necessary to remove the complete filter from the line. Disassembly is simple and does not require tools. Before disassembly, shut off the air supply and depressurize filter. Clean all parts with cleaning solvent and blow out filter body before reassembly. Wash filter element in cleaning solvent and blow out from the inside.

Automatic Drain

The automatic drain is equipped with a float actuated device which automatically ejects liquid contaminants under pressure.

Parts (Series B)

24U115	Automatic Drain
127289	O-Ring
16W811	Baffle End Cap
16W405	Filter Element

Coalescer w/Automatic Drain (Part No. 22605, Series B)

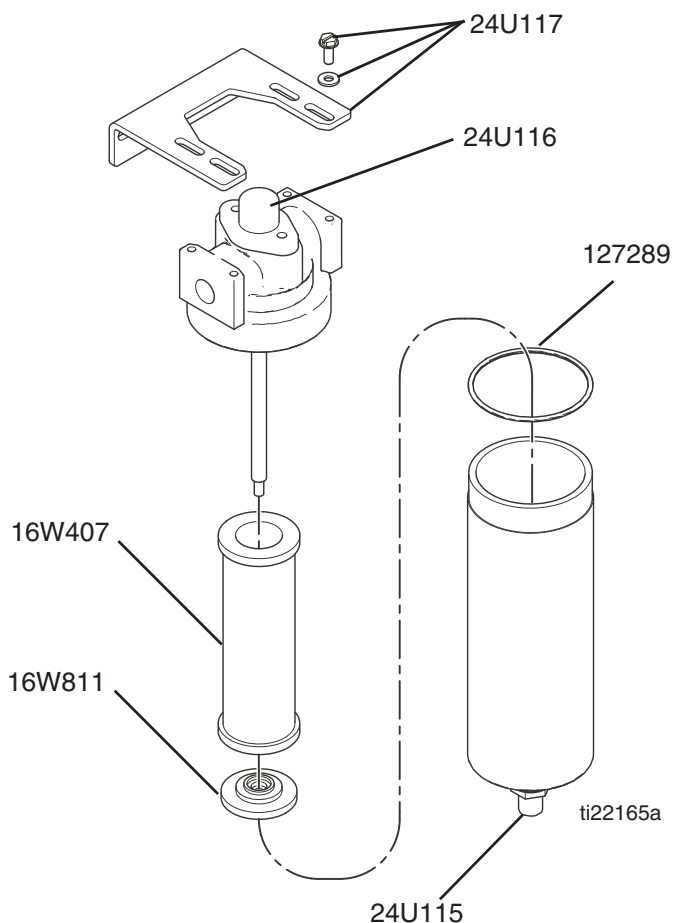

Installation

It is always recommended that a SHARPE air filter be installed upstream of the coalescing filter to remove 5 micron and larger size particles and separate large droplets of moisture from the air line.

Maintenance

To maintain maximum filtering efficiency and to avoid excessive pressure drop, the filter must be kept clean. Bowl drainage is automatic with the float drain. Remove the bowl to drain manually. A visible coating of dirt on the filter element surface or an excessive pressure drop is an indication that cleaning is necessary.

Cleaning

To clean, it is not necessary to remove the complete filter from the line. Disassembly is simple and does not require tools. Before disassembly, shut off the air supply and depressurize coalescer. Clean all parts with cleaning solvent and blow out body before reassembly. Replace coalescing element (part no. 16W407).

Pressure Drop Indicator

The differential pressure drop indicator on this unit is designed to provide early detection of a clogged coalescing filter element. As the filter element becomes clogged the red indicator will start to rise while air is flowing through the unit. When the pressure drop across the element reaches 10-12 psi (0.07-0.08 MPa, 0.7-0.8 bar) the red indicator will be in full view and the element should be replaced. Failure to replace the element when the pressure drop exceeds 10 psi (0.07 MPa, 0.7 bar) will affect your air quality and tool efficiency.

Automatic Drain

The automatic drain is equipped with a float actuated device which automatically ejects liquid contaminants under pressure.

Parts (Series B)

24U115	Automatic Drain
24U117	Mounting Bracket Kit
127289	O-Ring
16W811	Baffle End Cap
24U116	Pop-up Indicator Repair Kit
16W407	0.01 Micron Coalescer Element

DRYAIR MEMBRANE AIR DRYING SYSTEM

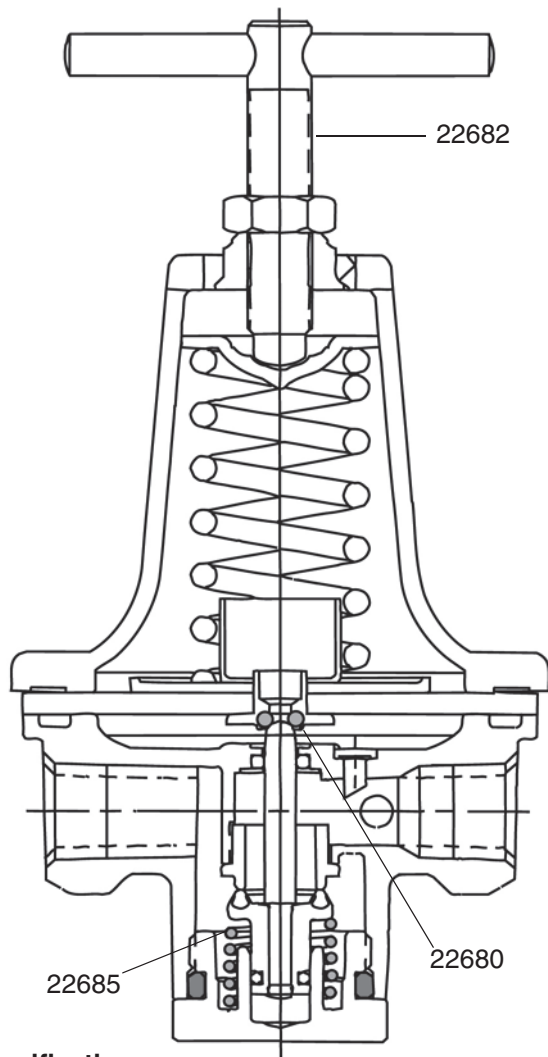

I

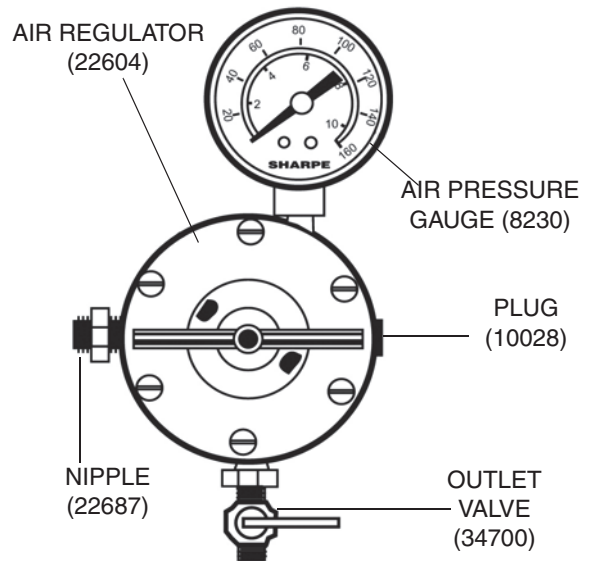

Self-Relieving Air Regulator (Part No. 22604)

Maintenance

If the air supply is kept clean, this regulator will provide long periods of uninterrupted service. Erratic regulator operation or loss of regulation is most always due to dirt in the diaphragm area and cleaning is in order.

Cleaning

Depressurize regulator, remove bottom plug, spring valve, and diaphragm. Clean parts with denatured alcohol, wipe off seat and blow out body with compressed air. Reassemble parts as a unit and screw into regulator before tightening bottom plug. Make sure disc is in center hole in body. Should regulator continue to malfunction, obtain diaphragm/valve repair kit (part no. 22680) and replace parts provided.

Specifications

Air Inlet 3/8 in. F.P.T.

Air Outlet 1/4 in. F.P.T. (3 EA.)

Air Flow Capacity 100 cfm (2.8 m³/min.)

Max. Operating Pressure 160 psi (1.1 MPa, 11 bar)

Max. Temperature 150°F (65°C)

Parts

8230	Air Pressure Gauge
10028	Plug
22680	Diaphragm/Valve Repair Kit
22682	T-Handle Adjusting Screw
22685	Bottom Spring
22687	3/8 in. x 3/8 in. Nipple
34700	Outlet Valve

DRYAIR MEMBRANE AIR DRYING SYSTEM

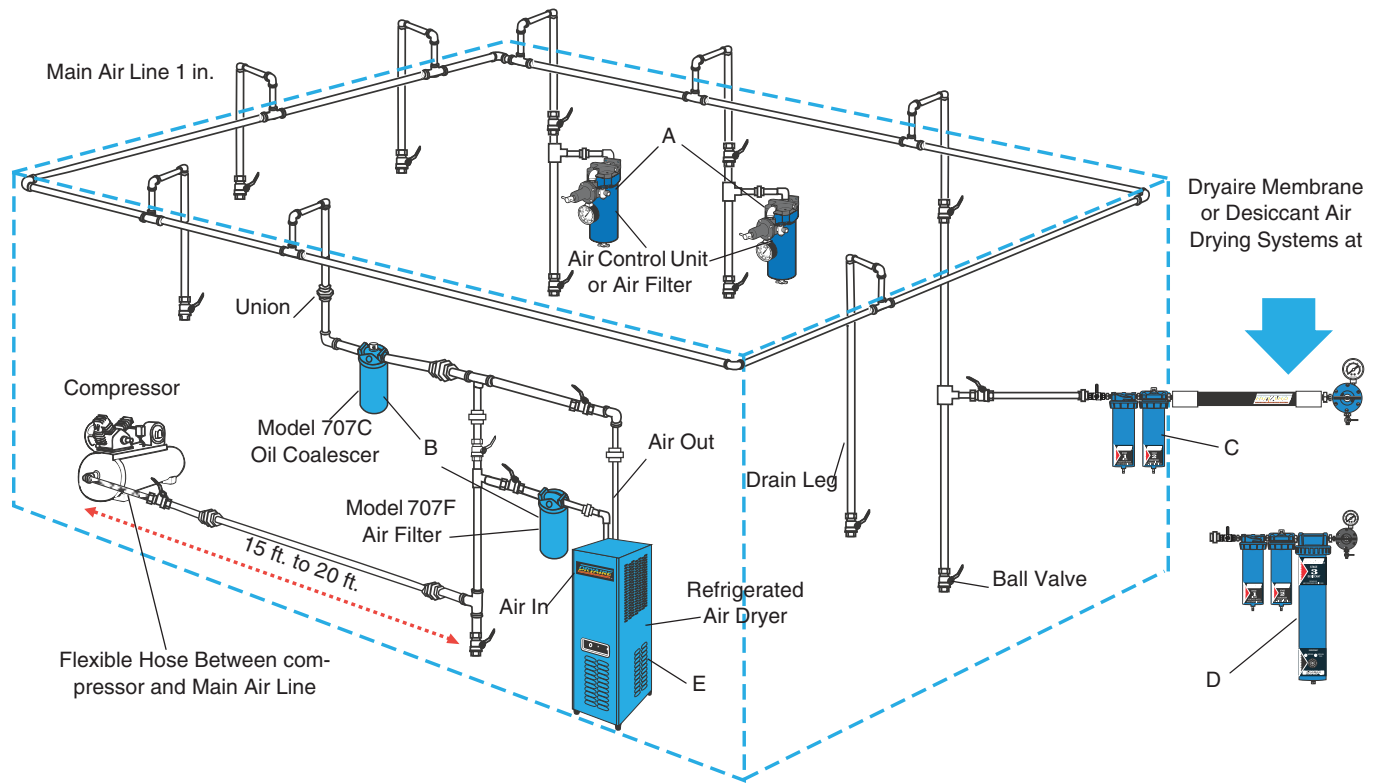

Ref. Letter	Description	
A	Sharpe 606	U06710
	Sharpe 606A	U06720
	Sharpe 606B	6730
	Sharpe 880A	6950
	Sharpe F88	8130
B	707C	6930
	707F	6920
	707FC	6910
C	Dryaire Membrane	6770
D	Dryaire Desiccant	6760
E	Refrigerated Air Dryer	
	25CFM	6880
	35CFM	6885
	50CFM	6890
	75CFM	6895

1 Year Limited Warranty

Sharpe warrants this product to the original user against defective material or workmanship for a period of 1 year from the date of purchase.

Sharpe reserves the right to determine whether the part or parts failed because of defective material, workmanship, or other causes. Failures caused by accident, alteration, or misuse are not covered by this warranty.

Sharpe, at its discretion, will repair or replace products covered under this warranty free of charge. Repairs or replacements of products covered under this warranty are warranted for the remainder of the original warranty period.

Sharpe or its authorized service representatives must perform all warranty repairs. Any repair to the product by unauthorized service representatives voids this warranty. The rights under this warranty are limited to the original user and may not be transferred to subsequent owners.

This warranty is in lieu of all other warranties, expressed or implied, including warranties of merchantability and fitness for a particular purpose. Some states do not allow the exclusion or limitations of incidental or consequential damages, so the above limitations may not apply to you.

Sharpe Information

TO PLACE AN ORDER, contact your SHARPE distributor or call 1-800-742-7731 or visit our web site at www.sharpe1.com.

Product Registration

Thank you for the purchase of your Sharpe® product. We greatly appreciate your business.

Important reasons to register your product:

- Registration enables Sharpe to notify you if there is a problem with your product.
- Improved Product Development - Your input helps us continue to design products that meet your needs.

For the most up-to-date information and to register your product, please go to www.sharpe1.com and click on "Register Product."

All written and visual data contained in this document reflects the latest product information available at the time of publication. Graco reserves the right to make changes at any time without notice.

Original instructions. This manual contains English. MM 310596

SHARPE MANUFACTURING • P.O. BOX 1441, MINNEAPOLIS, MN 55440-1441
1-800-742-7731, www.sharpe1.com

Copyright 2006, Graco Inc. All Graco manufacturing locations are registered to ISO 9001.
Revision H, September 2013