

D-5-55

Siphon Feed Detail Spray Gun

309991E

ENG

For siphon feed spraying of automotive colors and clears. Ideal for touch-up and detail work.



Important Safety Instructions

Read all warnings and instructions in this manual. Save these instructions.

Maximum Air Inlet Pressure: 50 psi (345 kPa, 3.4 bar)

Part No. 7030 Spray Gun and 7510 Cup



WARNING



FIRE AND EXPLOSION HAZARD

Flammable fumes, such as solvent and paint fumes, in **work area** can ignite or explode. To help prevent fire and explosion:

- Use equipment only in well ventilated area.
- Eliminate all ignition sources; such as pilot lights, cigarettes, portable electric lamps, and plastic drop cloths (potential static arc).
- Keep work area free of debris, including solvent, rags and gasoline.
- Do not plug or unplug power cords, or turn power or light switches on or off when flammable fumes are present.
- Ground all equipment in the work area. See **Grounding** instructions.
- Use only grounded hoses.
- Hold gun firmly to side of grounded pail when triggering into pail.
- If there is static sparking or you feel a shock, **stop operation immediately**. Do not use equipment until you identify and correct the problem.
- Keep a working fire extinguisher in the work area.



EQUIPMENT MISUSE HAZARD

Misuse can cause death or serious injury.

- Do not operate the unit when fatigued or under the influence of drugs or alcohol.
- Do not exceed the maximum working pressure or temperature rating of the lowest rated system component. See **Technical Data** in all equipment manuals.
- Use fluids and solvents that are compatible with equipment wetted parts. See **Technical Data** in all equipment manuals. Read fluid and solvent manufacturer's warnings. For complete information about your material, request MSDS from distributor or retailer.
- Do not leave the work area while equipment is energized or under pressure. Turn off all equipment and follow the **Pressure Relief Procedure** when equipment is not in use.
- Check equipment daily. Repair or replace worn or damaged parts immediately with genuine manufacturer's replacement parts only.
- Do not alter or modify equipment.
- Use equipment only for its intended purpose. Call your distributor for information.
- Route hoses and cables away from traffic areas, sharp edges, moving parts, and hot surfaces.
- Do not kink or over bend hoses or use hoses to pull equipment.
- Keep children and animals away from work area.
- Comply with all applicable safety regulations.



PRESSURIZED EQUIPMENT HAZARD

Fluid from the gun/dispense valve, leaks, or ruptured components can splash in the eyes or on skin and cause serious injury.

- Follow the **Pressure Relief Procedure** when you stop spraying and before cleaning, checking, or servicing equipment.
- Tighten all fluid connections before operating the equipment.
- Check hoses, tubes, and couplings daily. Replace worn or damaged parts immediately.

WARNING



TOXIC FLUID OR FUMES HAZARD

Toxic fluids or fumes can cause serious injury or death if splashed in the eyes or on skin, inhaled, or swallowed.

- Read MSDSs to know the specific hazards of the fluids you are using.
- Store hazardous fluid in approved containers, and dispose of it according to applicable guidelines.



PERSONAL PROTECTIVE EQUIPMENT

You must wear appropriate protective equipment when operating, servicing, or when in the operating area of the equipment to help protect you from serious injury, including eye injury, hearing loss, inhalation of toxic fumes, and burns. This equipment includes but is not limited to:

- Protective eyewear, and hearing protection.
- Respirators, protective clothing, and gloves as recommended by the fluid and solvent manufacturer.

Setup



- Set shop air pressure regulator (not supplied) according to paint manufacturer's recommendation. Do not exceed 50 psi (345 kPa, 3.4 bar).
 - Make sure no air restrictions, such as low-volume cheater-valves, obstruct the air flow. If an air adjusting valve is desired, use a SHARPE Air Adjusting Valve 24AAV (part no. 2210), 36AAV-HOV (part no. 3310) or HOV (part no. U04410).
 - Install a shutoff valve (not supplied) downstream of the air regulator to shut off gun air.
 - Install an inline air filter (not supplied) to clean and dry the air supply to the gun.
1. Turn off air supply.
 2. Connect a clean, dry, filtered air supply to gun air inlet (2).
 3. If this is first time using the equipment, flush the spray gun.



FIG. 1

Operation



Pressure Relief Procedure

| | | | | | | |
|---|---|--|--|--|--|--|
|  |  | | | | | |
|---|---|--|--|--|--|--|

Follow **Pressure Relief Procedure** when you stop spraying and before cleaning, checking, or servicing equipment. Read warnings, page 2.

1. Turn off gun air supply.
2. Trigger the gun to relieve pressure.

Flushing

| | | | | | | |
|---|---|---|--|--|--|--|
|  |  |  | | | | |
|---|---|---|--|--|--|--|

Flush before using the equipment, before changing colors, and when you are done spraying. Use solvent that is compatible with gun wetted parts and fluid that will be sprayed. Flush at lowest possible pressure.

NOTE: Refer to **Compliant Cleaning Methods**, page 5, to comply with air quality laws if applicable.

1. Follow **Pressure Relief Procedure**.
2. Dispose of any paint in cup.
3. Fill cup with small amount of solvent.
4. Spray into grounded metal waste container until equipment is clean.
5. Follow **Pressure Relief Procedure**.

Spraying

| NOTICE |
|---|
| Excessive atomizing air pressure can increase over-spray, reduce transfer efficiency, and result in a poor quality finish from dry spray. |

1. Fill cup (101) with material. Do not fill past cup “shoulder” (A). See FIG. 1.
2. Screw cup (101) onto lid securely.
3. Slowly adjust gun air pressure while fully triggering the gun until you have the desired atomization.
4. Adjust the pattern size and shape with the spray width adjustment knob (10). See FIG. 2. Turn knob clockwise to reduce pattern size and counterclockwise to increase it.

NOTE: See **Troubleshooting** guide if you experience an irregular pattern.

5. Fluid control knob (7) is factory set for maximum needle trigger travel and material flow. To decrease needle/trigger travel and decrease fluid flow, turn knob clockwise.

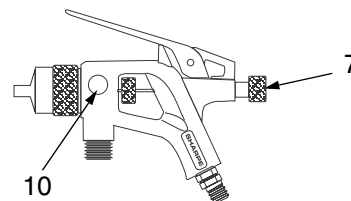

FIG. 2

Cleaning and Maintenance



NOTICE

- Do not submerge gun in solvent. Solvent dissolves lubricant, dries out packings, and may clog air passages.
- Do not use metal tools to clean air cap holes as this may scratch them and distort the spray pattern.
- Use a compatible solvent.
- Gun and cup can be cleaned in a gun washer.

NOTE: Clean air line filters as directed by the manufacturer.

Volatile Organic Compounds (VOC) Regulation

In certain states, spraying solvents that release VOC's into the atmosphere when cleaning a spray gun is prohibited. To comply with these air quality laws you must use a cleaning method that prevents the escape of VOC vapors into the atmosphere. See **Compliant Cleaning Methods** below.

Compliant Cleaning Methods

- Place spray gun in a gun washer that completely encloses the gun and components during cleaning, rinsing, and draining.
- Spray solvent through the spray gun into a closed gun cleaning station.

Cleaning Gun and Cup

NOTE: Refer to **Compliant Cleaning Methods** to comply with air quality laws if applicable.

1. Follow **Flushing** procedure, page 4.
2. Use a rag moistened in solvent to wipe cup lid (109), fluid tube (103), inside of cup (101), and outside of gun.
3. Blow dry gun inside and out. Lubricate gun as described in **Spray Gun Maintenance**.

Cleaning Nozzle and Air Cap

NOTICE

- Trigger gun whenever you tighten or remove nozzle to avoid damaging needle seat and nozzle.
- Do not use metal tools to clean air cap holes as this may scratch them and distort the spray pattern.

To clean the air cap and nozzle, remove and soak them in a compatible cleaning solution. Clean them and front of gun with a soft-bristle brush dipped into compatible solvent. Do not use a wire brush or metal tools. To clean out air cap holes, use a soft implement, such as a toothpick.

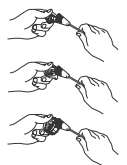





Spray Gun Maintenance

- Frequently lubricate the gun moving parts with a drop of non-silicone oil (part no. 8255).
- Do not disassemble the spray gun if you are having a spray pattern problem. Check **Troubleshooting**, page 6, for information on how to correct the problem.
- Check for fluid leakage. Tighten fittings or replace equipment as needed.

Troubleshooting



| Problem | Cause | Solution |
|---|--|---|
|  Right | Normal pattern | No action necessary |
|  Wrong Heavy top or bottom pattern | Dirty or damaged air cap or fluid nozzle. | Rotate air cap 180°. <i>If pattern follows air cap, problem is in air cap. Clean and inspect. If pattern is not corrected, replace air cap.</i> <i>If pattern does not follow the air cap, the problem is with the fluid nozzle. Clean and inspect the nozzle. If the pattern is not corrected, replace nozzle.</i> |
|  Wrong Split pattern | Pressure too high for viscosity of material being sprayed. | a. Reduce air pressure. b. Increase material viscosity c. Correct pattern by narrowing fan size with spray width adjustment knob. |
|  Wrong | Dirty or distorted air horn holes. | Rotate air cap 180°. <i>If pattern follows air cap, problem is in air cap. Clean and inspect. If pattern is not corrected, replace air cap.</i> |
| Will not spray. | a. Cup is not tight b. Cup empty. c. Air cap not seated. | a. Tighten cup lid. b. Fill cup. c. Turn spray width adjustment knob fully counter-clockwise. Tighten air cap. |
|  Wrong Heavy pattern or orange peel | a. Air pressure too low. b. Gun held too close to surface. | a. Increase air pressure. b. Hold gun about 6-8 inches (150-200 mm) from surface. |

Technical Data

Maximum Air Inlet Pressure: 50 psi (345 kPa, 3.4 bar)

Wetted Parts: stainless steel, aluminum, brass, LD polyethylene

Air Consumption: 4.1 scfm at 50 psi (345 kPa, 3.4 bar)

Spray Gun

- 1/4 npsm (R1/4-19) air inlet
- 1/4 npsm fluid inlet
- Weight - 8 oz. (227 grams)

Pressure cup: 6 oz. (177 cc)

Parts

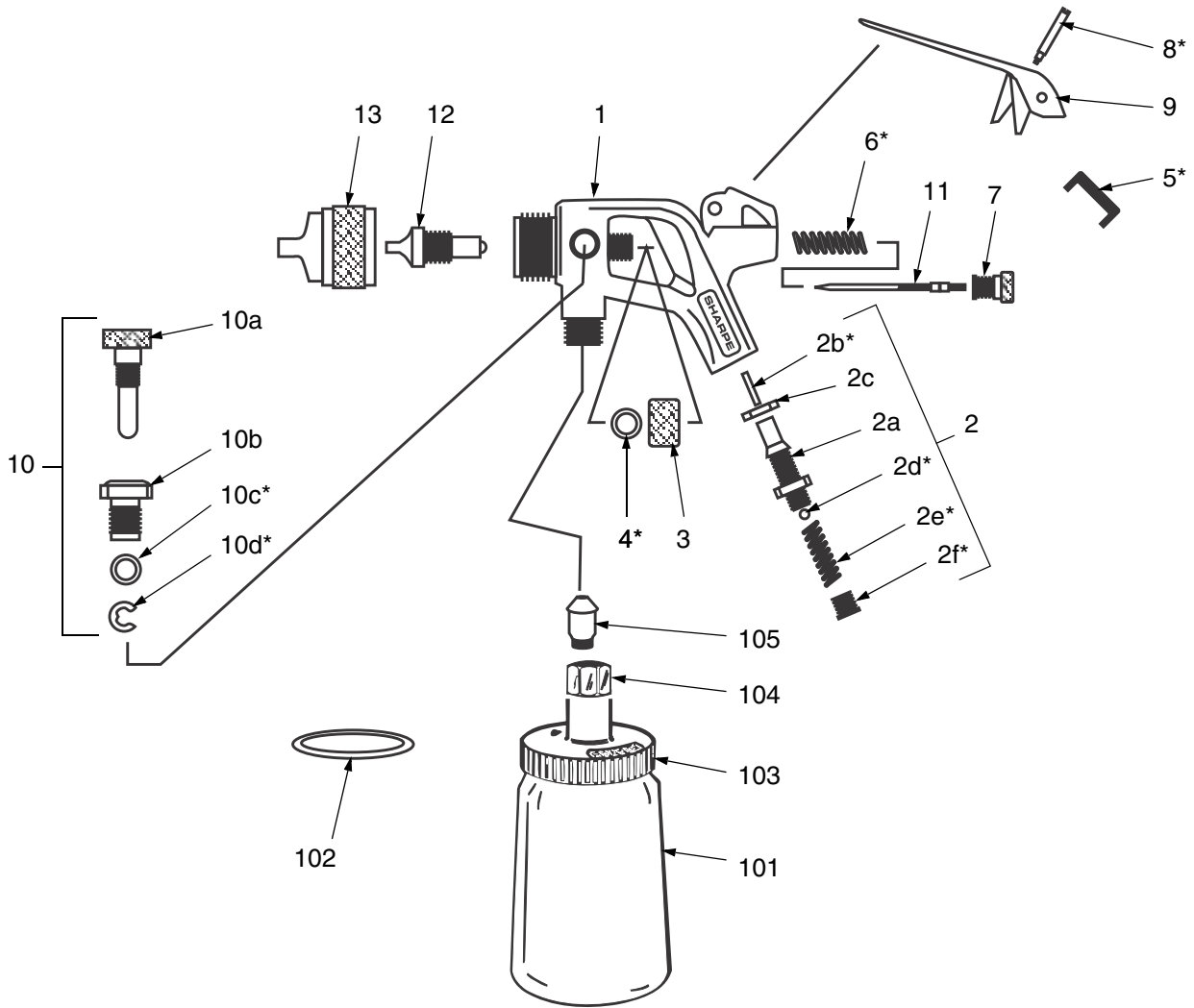

Part No. 7030, D-5-55 Detail Spray Gun

| Ref. No. | Part No. | Description | Qty. |
|----------|----------|--|------|
| 1 | 29001 | Gun Body | 1 |
| 2 | 29054 | Air Valve Assembly Includes items 2a-2f | 1 |
| 2a | 34819 | • Housing | 1 |
| 2b* | 29049 | • Air Valve Stem | 1 |
| 2c | 29053 | • Lock Nut | 1 |
| 2d* | 29050 | • Ball | 1 |
| 2e* | 29036 | • Needle Spring | 1 |
| 2f* | 29052 | • Retainer | 1 |
| 3 | 29033 | Needle Packing Nut | 1 |
| 4* | 26022 | Needle Packing | 1 |
| 5* | 29047 | Plunger | 1 |
| 6* | 29036 | Needle Spring | 1 |
| 7 | 29046 | Fluid Control Knob | 1 |
| 8* | 29056 | Trigger Screw | 1 |
| 9 | 29055 | Trigger | 1 |
| 10 | 29030 | Width Control Assembly Includes items 10a-10d | 1 |

| Ref. No. | Part No. | Description | Qty. |
|----------|----------|--------------------|------|
| 10a | 118749 | • Knob | 1 |
| 10b | 118741 | • Packing Nut | 1 |
| 10c* | 29028 | • Packing | 1 |
| 10d* | 29029 | • Retaining Ring | 1 |
| 11 | 29041 | Fluid Needle | 1 |
| 12 | 29021 | Fluid Nozzle, 0.55 | 1 |
| 13 | 29006 | Air Cap | 1 |

* Parts included in Repair Kit 29086.

Part No. U07510, D-500 Cup Assembly

| Ref. No. | Part No. | Description | Qty. |
|----------|----------|--------------------------|------|
| 101 | U07530 | Cup with air-tight cover | 1 |
| 102 | 29063 | Gasket, pack of 5 | 1 |
| 103 | 29062 | Lid with Fluid Tube | 1 |
| 104 | 29057 | Coupling Nut | 1 |
| 105 | 29058 | Nipple Fitting | 1 |

2 Year Limited Warranty

Sharpe warrants this product to the original user against defective material or workmanship for a period of 2 years from the date of purchase.

Sharpe reserves the right to determine whether the part or parts failed because of defective material, workmanship, or other causes. Failures caused by accident, alteration, or misuse are not covered by this warranty.

Sharpe, at its discretion, will repair or replace products covered under this warranty free of charge. Repairs or replacements of products covered under this warranty are warranted for the remainder of the original warranty period.

Sharpe or its authorized service representatives must perform all warranty repairs. Any repair to the product by unauthorized service representatives voids this warranty. The rights under this warranty are limited to the original user and may not be transferred to subsequent owners.

This warranty is in lieu of all other warranties, expressed or implied, including warranties of merchantability and fitness for a particular purpose. Some states do not allow the exclusion or limitations of incidental or consequential damages, so the above limitations may not apply to you.

Sharpe Information

TO PLACE AN ORDER, contact your SHARPE distributor or call 1-800-742-7731 or visit our website at www.sharpe1.com.

Product Registration

Thank you for the purchase of your Sharpe® product. We greatly appreciate your business.

Important reasons to register your product:

- Registration enables Sharpe to notify you if there is a problem with your product.
- Improved Product Development - Your input helps us continue to design products that meet your needs.

For the most up-to-date information and to register your product, please go to www.sharpe1.com and click on "Register Product."

All written and visual data contained in this document reflects the latest product information available at the time of publication. Graco reserves the right to make changes at any time without notice.

Original instructions. This manual contains English. MM 309991

SHARPE MANUFACTURING • P.O. BOX 1441, MINNEAPOLIS, MN 55440-1441
1-800-742-7731, www.sharpe1.com

Copyright 2004, Graco Inc. is registered to ISO 9001
Revised 02/2011